



# CHAPTER 215. ZONING CODE

## Part 3. Development Standards

REVISED

FEBRUARY 1, 2024

# Table of Contents

- Article 30. Circulation, Access, & Parking .....4**
  - §215-30.1 Purpose & Intent..... 4
  - §215-30.2 Applicability..... 4
  - §215-30.3 Residential Parking Requirements ..... 5
  - §215-30.4 Off-Street Parking Space Requirements ..... 6
  - §215-30.5 Loading Space Requirements .....7
  - §215-30.6 Location Of Spaces .....7
  - §215-30.7 Design Requirements..... 8
  - §215-30.8 Alternative Parking Arrangements ..... 9
  - §215-30.9 Bicycle & Pedestrian Accommodations..... 11
  - §215-30.10 Access Management..... 13
- Article 31. Landscaping, Screening & Open Space.....15**
  - §215-31.1 Purpose & Intent..... 15
  - §215-31.2 Applicability..... 15
  - §215-31.3 Landscape Plan Requirements ..... 16
  - §215-31.4 Plant Material Requirements..... 17
  - §215-31.5 General Standards & Criteria ..... 18
  - §215-31.6 Lawn Area ..... 19
  - §215-31.7 Building Foundation Landscaping ..... 19
  - §215-31.8 Perimeter Landscaping & Trees..... 19
  - §215-31.9 Off-Street Parking & Loading Areas ..... 21
  - §215-31.10 Dumpster Screening ..... 23
  - §215-31.11 Mechanical Equipment Screening ..... 24
  - §215-31.12 Landscaping & Tree Maintenance ..... 24
  - §215-31.13 Open Space & Green Space ..... 24
- Article 32. Building & Site Design Standards.....26**
  - §215-32.1 Purpose & Intent..... 26
  - §215-32.2 Applicability..... 26
  - §215-32.3 Building Placement & Orientation..... 27
  - §215-32.4 Building Massing & Form..... 28
  - §215-32.5 Building Façades & Fenestration ..... 30
  - §215-32.6 Roof Styles & Treatments ..... 33
  - §215-32.7 Materials & Color..... 34
  - §215-32.8 Design Transitions Between Nonresidential & Residential Uses..... 35
  - §215-32.9 General Site Design Standards ..... 35
  - §215-32.10 Waterfront Viewshed Protection ..... 36

§215-32.11 Stormwater Management & Green Infrastructure ..... 36

**Article 33. Exterior Lighting .....38**

§215-33.1 Purpose & Intent..... 38

§215-33.2 Applicability..... 38

§215-33.3 Lighting Plan ..... 38

§215-33.4 Lighting Design ..... 39

§215-33.5 Intensity Of Illumination ..... 40

**Article 34. Signage .....41**

§215-34.1 Purpose ..... 41

§215-34.2 Applicability..... 41

§215-34.3 Sign Permit Required..... 41

§215-34.4 Sign Permit Applications..... 43

§215-34.5 Review Procedures ..... 44

§215-34.6 Measurement ..... 45

§215-34.7 Safety Provisions ..... 45

§215-34.8 Design & Construction..... 45

§215-34.9 Illumination..... 46

§215-34.10 Location ..... 47

§215-34.11 Maintenance & Repair..... 47

§215-34.12 Removal Of Signs ..... 47

§215-34.13 Signs Authorized Without A Permit ..... 48

§215-34.14 Prohibited Signs ..... 49

§215-34.15 Sign Design Guidelines ..... 50

§215-34.16 Regulations By Zoning District ..... 51

§215-34.17 Unique Building & Development Configurations..... 52

§215-34.18 Regulations By Sign Type ..... 52

§215-34.19 Digital Signs ..... 57

§215-34.20 Nonconforming Signs..... 58

# Article 30. Circulation, Access, & Parking

## §215-30.1

### PURPOSE & INTENT

---

- A. Purpose.** The purpose of this Article and intent of its regulations is to achieve the following objectives:
1. Ensure there are adequate amounts of off-street parking and loading facilities to serve the use(s) and users of the property;
  2. Protect the users of adjacent properties from nuisances caused by the noise, fumes, and glare of headlights which may result from the operation of vehicles;
  3. Reduce congestion on the primary street networks of the Town;
  4. Encourage alternative parking designs and modes of transportation to reduce the share of auto-dominated sites within the Town and dependence on single-occupancy vehicular trips;
  5. Minimize further expansion of impervious surfaces within the Town and reduce loss of green space;
  6. Provide safe traveling conditions and off-street accommodations for motorists, pedestrians, and bicyclists; and
  7. Ensure safe, well-planned multi-modal access is provided to all properties while minimizing potential vehicular, pedestrian, and bicyclist conflicts.
- B. Redevelopment.** These regulations are further intended to guide redevelopment of existing properties and new facilities in a manner compatible with the future development vision of the Town of Tonawanda. As redevelopment and investment takes place, emphasis should be placed on improving the aesthetics of the site and surrounding area, especially as it relates to commercial corridors and views along the waterfront.

## §215-30.2

### APPLICABILITY

---

- A. Uses Subject to Regulation.** All nonresidential, mixed-use, and multi-family development shall meet the requirements of this Article. No building or zoning permit shall be issued for any use that does not conform to the requirements herein.
- B. Residential Uses.** Single-, two-, and multi-family properties up to four units shall be exempt from the requirements of this Article, except for §215-30.3.
- C. Owners Responsibility.** The provision and maintenance of off-street parking and loading areas is a continuing obligation of the property owner.
- D. New Construction.** New construction and infill development shall be in conformance with all requirements of this Article, unless otherwise provided herein.
- E. Existing Sites.**

1. If an existing building, use, or occupancy is altered so that there is an increase in the minimum required off-street parking and loading spaces, the number of such spaces shall be provided at least equal to the number required for the increased area of the building or use in accordance with all provisions of this Article.
  2. Improvements to already developed sites shall follow the regulations of this Article to the greatest extent practicable. In the case of nonconformities, Subsection G shall apply.
- F. Substantial Improvements.** Where the total cost of proposed improvements to an existing site are 75% or more of the property's assessed value, all improvements shall be in full compliance with this Article.
- G. Nonconformity.** A building or site not in conformance with this Article may not be required to bring the entirety of such structure into conformance, if, in the opinion of the reviewing body, the proposed improvements to the property do not increase the level of nonconformity and are otherwise consistent with the intent of this Article.
- H. Property Owner Assistance.** Owners of existing sites are strongly encouraged to consult with Town Staff and/or all applicable review bodies for assistance in following these design guidelines prior to making exterior repairs, renovations, restorations, and alterations to their buildings.

### §215-30.3

### RESIDENTIAL PARKING REQUIREMENTS

- A. Regulations for Residential Uses.** The requirements of this section shall apply to all single-, two-, and multi-family uses and lots up to four units.
1. The minimum number of parking spaces shall be provided in accordance with §215-30.4 B.
  2. Parking may be permitted in the front yard area, provided all vehicles are located on an approved driveway. The driveway width shall be limited to the minimum and maximum width requirements of §215-30.10 E.
  3. Only one curbcut shall be allowed per residential lot and shall conform to the requirements of Chapter 183 (Streets and Sidewalks) of the Town of Tonawanda Code.
  4. Parking is prohibited on grass areas and yard space that is not hard-surfaced and properly designated for such use.
- B. Parking of Recreational Vehicles.** Parking of personal seasonal vehicles, boats, trailers, or recreational vehicles is permitted, provided such vehicles:
1. Are registered and licensed;
  2. Are not used for living purposes;
  3. Are not parked within the front yard area;
  4. Are parked on an approved surface; and
  5. Do not obstruct vehicular, pedestrian, or bicyclist vision and access.
- C. Maximum Vehicle Weight.** No portion of a residential property located in a residential district shall be occupied at any time by any vehicle having a

maximum gross load weight in excess of five tons unless said vehicle is stored and kept entirely within an enclosed structure when on the premises.

§215-30.4

OFF-STREET PARKING SPACE REQUIREMENTS

A. Number of Parking Spaces.

1. The requirement for a single use (e.g. a retail store) shall be determined directly from this section, unless otherwise noted within this Chapter.
2. The requirements for a combination of uses (e.g. a retail store with an office building) shall be determined by establishing the requirement for each single use and adding them together, unless otherwise noted herein.
3. For uses not specifically listed, the requirement shall be the same as for the most similar listed use as determined by the Code Enforcement Officer.

B. Parking Minimums. The minimum number of off-street parking spaces per use shall be in conformance with the following:

LAND USE	MINIMUM SPACES
<b>Residential</b>	
<i>Single-Family Dwelling</i>	2 per unit
<i>Multi-Family Dwelling</i>	1.5 per unit
<b>Commercial / Industrial</b>	
<i>Retail Shop</i>	3 per 1,000 sf of gross floor area
<i>Service Shop</i>	2 per 1,000 sf of gross floor area
<i>Office or Clinic</i>	1 per employee <sup>1</sup>
<i>Restaurant or Bar</i>	4 per 1,000 sf of gross floor area
<i>Recreation or Entertainment Facility</i>	0.25 per maximum occupancy
<i>Industrial Operation</i>	1 per employee <sup>1</sup>
<b>Other</b>	
<i>Hospital</i>	1 per bed + 1 per employee <sup>1</sup>
<i>Place of Worship or Public Assembly</i>	0.25 per maximum occupancy
<i>Marina</i>	1 per boat slip
<i>School</i>	1 per classroom + 1 per employee <sup>1</sup>

NOTE: (1) Per employee at maximum shift.

- C. **Parking Maximums.** The maximum number of parking spaces allowable for any use shall not exceed 120% of the minimum requirement, except through the submission of a parking demand analysis in accordance with §215-30.8(E) and development plan approval.
- D. **Size of Parking Spaces.** The size off off-street parking spaces and aisles shall conform to the following dimensional standards:

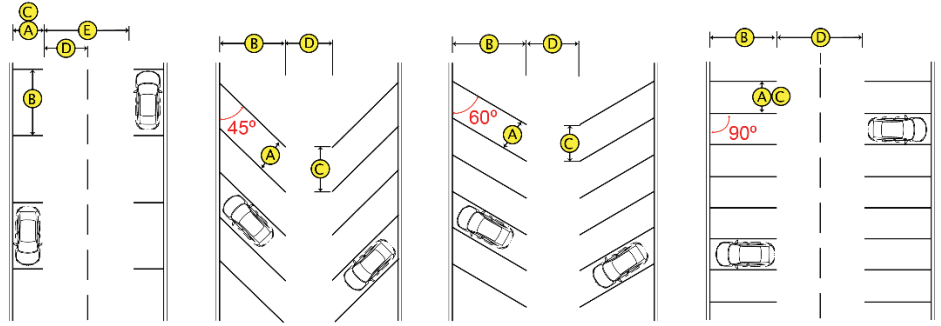

STALL ANGLE	STALL WIDTH (A)	STALL LENGTH (B)	SKEW WIDTH (C)	DRIVE AISLE WIDTH (D)		
	MIN	MIN	MIN	ONE-WAY MIN	TWO-WAY MIN	MAX
0°	8 ft	18 ft	8 ft	11 ft	22 ft	24 ft
45°	9 ft	17 ft	11 ft	12 ft	22 ft	24 ft
60°	9 ft	20 ft	9 ft	14 ft	22 ft	28 ft
90°	9 ft	18 ft	9 ft	11 ft	22 ft	24 ft

§215-30.5

LOADING SPACE REQUIREMENTS

- A. **Applicability.** Whenever the normal operation of any use requires that goods, merchandise, or equipment be routinely delivered to or shipped from that use, off-street loading areas must be provided in accordance with this section.
- B. **Minimum Spaces Required.** Loading spaces shall be provided for uses in accordance with the table below.

GROSS FLOOR AREA (SF)	MINIMUM SPACES	MINIMUM SIZE
Less than 5,000	0	-
5,000 to 10,000	1	12 by 25 ft
10,000 to 30,000	1	14 by 50 ft
Each additional 15,000	+1	14 by 50 ft

- C. **Deliveries.** Where loading spaces are located within 100 feet of a residential use or district there shall be no deliveries between the hours of 10:00PM and 7:00AM EST.
- D. **Green Loading Zones.** The provision of green loading zones is highly encouraged. Where such zones may be reasonably accommodated on-street, the number of spaces provided may count towards the off-street loading space requirements of this section.

§215-30.6

LOCATION OF SPACES

- A. **Front Yard.**

1. No off-street parking spaces shall be located in the front yard area, with the exception of a single row of parking spaces and the necessary access road to said spaces.
  2. At least 50% of the convenience parking area frontage shall be screened from the public right-of-way in accordance with §215-31.9 B.
  3. No off-street loading spaces shall be permitted in the front yard area or fronting a primary street.
- B. Side Yard.** Off-street parking areas may be permitted in the side yard when in compliance with the following standards:
1. The overall width of the parking area frontage does not exceed 30% of the lot width. **See Figure 30.1.**
  2. The paved parking area is at least 10 feet behind the front building line. Where no primary structure is provided on a lot, the parking area shall meet the minimum setback requirements or be located at least 10 feet behind the front building line of an adjacent property, whichever is greater. **See Figure 30.1.**

**FIGURE 30.1 Side Yard Parking**

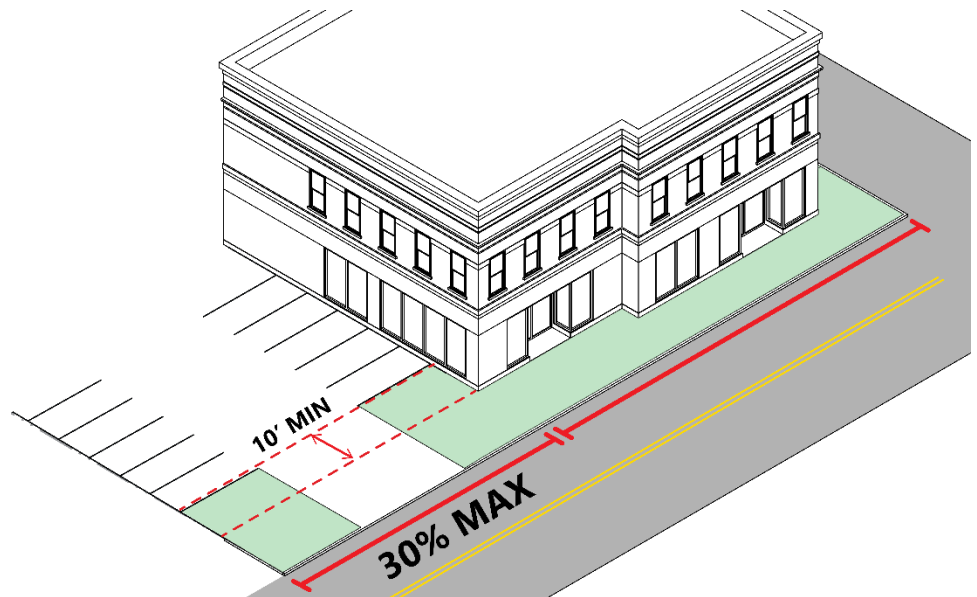

- C. Same Lot Requirement.** All off-street parking and loading spaces shall be on the same lot as the use they are intended to serve, unless otherwise allowable with an alternative parking arrangement.
- D. Distance from Residential Property.**
1. Parking areas shall maintain a setback of at least 10 feet from abutting residential use or district property lines, unless otherwise approved as part of development plan review.
  2. Loading spaces and delivery areas shall maintain a setback of at least 30 feet from abutting residential use or district property lines.



All off-street parking and loading areas, including their vehicular access drives and pedestrian, and bicyclist connections, shall conform to the requirements of the Town of Tonawanda Design and Construction Standards and the following:

**A. Paving Materials.**

1. Acceptable surfacing materials shall be those capable of being kept in a smooth, well-graded condition, free of snow and debris. This includes concrete, asphalt, blacktop, brick, or other such properly engineered paving material with approval by the reviewing body. The use of pervious paving material is highly encouraged.
2. Prohibited surfacing treatments include dirt, gravel, pavement millings, or loose stone unless otherwise provided for by Subsection 4, the use of these materials may be permitted in the GI or MU-I districts as part of site plan review.
3. All areas shall be constructed to withstand the loads to be imposed by the vehicles for which the parking or loading area is intended.
4. To prevent the unnecessary paving of lands, emergency fire lanes or other areas and access drives not intended for daily use may be left unpaved and maintained as stone with review board approval. Such areas and drives shall remain unobstructed and in navigable condition to ensure vehicular accessibility at all times.

**B. Markings.**

1. Parking and loading spaces shall be properly marked with clear and permanent painted strips of at least four inches in width.
2. Areas designated for pedestrian and/or bicyclist access and use shall also be clearly delineated in this manner, unless otherwise separated by curbing or some other physical barrier.

**C. Landscaping and Screening.** All off-street parking and loading areas shall be landscaped and screened in accordance with Article 31.

**D. Lighting.** The exterior lighting of parking and loading areas shall be in conformance with the provisions of Article 33.

**E. Snow Storage.** All parking and loading areas must include a dedicated area for the placement and storage of snow.

**F. Stormwater Management.** All parking and loading areas shall conform to the stormwater management regulations of §215-32.11.

**G. Electric Vehicle Charging Stations.** Off-street parking and loading spaces may include charging stations for use by electric vehicles in accordance with §215-24.12.

## §215-30.8

### ALTERNATIVE PARKING ARRANGEMENTS

**A. On-Street and Municipal-Owned Parking.** On-street and municipally owned parking spaces may be used to satisfy the minimum off-street parking

requirement, in whole or in part, at the discretion of the reviewing body. Such spaces must be located within 1,000 feet of the use.

- B. Public Transit Access.** A public transit stop or station may be used to satisfy up to 15% of the minimum off-street parking requirement, provided the transit stop or station is located within 1,000 feet of the use.
- C. Compact Parking.**
  - 1. Compact parking may comprise up to 30% of the required spaces.
  - 2. Compact spaces must be clearly designated on the site.
  - 3. Compact spaces must have dimensions of no less than seven feet in width and 14 feet in length.
- D. Stacked or Valet Parking.**
  - 1. Stacked or valet parking is allowed if an attendant is present to move vehicles.
  - 2. If stacked parking is proposed to be used for all or a portion of required parking spaces, a written guarantee must be filed with the Town ensuring that an attendant will be present when the lot is in operation.
  - 3. The requirements for minimum or maximum spaces and other applicable parking area development standards continue to apply for stacked parking.
- E. Parking Demand Analysis.**
  - 1. The number of parking spaces required for any use may be adjusted with the completion of a parking demand analysis by the applicant and approval by the reviewing body.
  - 2. A parking demand analysis may be required where shared parking is proposed to determine the sharing factor.
  - 3. Such analysis shall include, at a minimum:
    - a. The names and addresses of the owner(s) and tenant(s) that will be using the parking;
    - b. An estimate of the number of spaces needed to accommodate the proposed use(s);
    - c. A summary and map of the proposed location and configuration of spaces (on-site, public lots, on-street, joint, shared, etc.);
    - d. A market study and/or other supporting information and rationale behind the requested number of parking spaces; and
    - e. An analysis of existing parking conditions in the surrounding area, to include a radius of at least 1,000 feet.
  - 4. The reviewing body may waive a parking demand analysis and the requirements thereof in whole or in part in accordance with §215-40.4 G.
- F. Joint or Shared Parking and Loading Spaces.**
  - 1. Where two or more uses are located on the same lot or located on separate lots, an applicant may propose the use of joint or shared parking and/or loading spaces.

2. Such arrangements may be authorized by the reviewing body as part of development plan review, provided the following conditions are met:
  - a. The parking area is located within 1,000 feet of the building(s) or use(s) it is intended to serve.
  - b. The loading area is within 100 feet of the building(s) or use(s) it is intended to serve.
  - c. The minimum number of spaces provided is at least that of the use with the greatest requirement or otherwise compliant with an approved parking demand analysis.
  - d. It is proven that the uses have different peak hour demands, or the total demand at peak times is adequately served by the total number of spaces proposed.
  - e. A Joint or Shared Access Agreement is executed documenting all uses and property owners. Such agreement shall be reflected in a deed, lease, contract, easement or other appropriate legal document.
  - f. A Maintenance Agreement is executed documenting the responsibility of each user and/or property owner in the maintenance and upkeep of such parking and/or loading areas.
3. Applicants seeking authorization of such arrangement shall submit written documentation justifying their requests, including:
  - a. The names and addresses of the owner(s) and tenant(s) that will be using the parking and/or loading spaces.
  - b. A description of the uses involved, including their minimum individual parking and/or loading requirements determined by this Article.
  - c. The location, design, and number of parking and/or loading spaces that are proposed, including the number to be shared and/or reserved for a certain use, where applicable.
  - d. A parking demand analysis in accordance with Subsection E above to determine the appropriate sharing factor. To be approved, this analysis must show that the uses have differing peak parking or loading times or that users overlap in visiting more than one use during peak times and that the proposed spaces will be adequate for the anticipated demands of each use.
  - e. The required access and maintenance agreements as outlined Subsection F (2).
4. Joint or shared parking and loading areas shall provide for cross access with clearly delineated vehicular drive aisles. Separation of joint or shared parking areas by a wall, guard rail, or other structure preventing vehicular access shall be prohibited, unless otherwise approved by the reviewing body.

## §215-30.9

## BICYCLE & PEDESTRIAN ACCOMMODATIONS

### A. Bicycle Parking.

1. Bicycle parking may be required of all nonresidential development at a rate of at least 10% of vehicle parking requirements at the discretion of the reviewing body.
2. This requirement shall not apply to properties within zoning districts where there are publicly provided or shared bicycle parking facilities within 1,000 feet of the use.

**B. Pedestrian Connectivity.**

1. Off-street parking areas of five or more spaces shall include a clearly identified pedestrian pathway from the parking spaces to building entrances and uses on site.
2. Pedestrian connections to the public sidewalk shall also be required, where applicable. **See Figure 30.2.**

**FIGURE 30.2 Pedestrian Sidewalk Network**



3. Pedestrian paths shall be a minimum of six feet wide. Pedestrian paths shall be distinguished from the parking area by grading or other protective device.
4. Pedestrian paths shall be located so the pedestrian has a short and efficient walking route.
5. Abutting land uses and buildings on a site shall be connected by a pedestrian path.

6. Pedestrian paths connecting off-street parking spaces to a building or use entrance shall be provided at a ratio of one pedestrian path for every four parking rows or 140 feet of parking lot width, whichever is greater.

## §215-30.10

### ACCESS MANAGEMENT

- A. **Access Required.** All off-street parking and loading spaces shall have direct access to a public street or alley.
- B. **Joint or Shared Access.**
  1. To promote more efficient traffic flow and traffic safety and minimize the number of curbcuts, every effort shall be made to provide shared means of ingress and egress to developed and developing properties.
  2. Where deemed necessary and appropriate, the reviewing body may require the provision of shared access drives and/or cross-easement agreements for rear access lanes to adjacent properties which minimize curbcuts along the primary roadway (see Figure 30.3).

**FIGURE 30.3** Vehicular Cross Access



- C. **Delineation.** Access from streets to parking and loading areas shall be clearly defined. All curbcuts shall be delineated with raised curbing.
- D. **Driveway Separation.** No access driveway shall be located closer than 50 feet to the intersection of public streets or another driveway. This minimum

separation may be increased or decreased with review body approval or where otherwise required by the Erie County or New York State Departments of Transportation.

- E. Driveway Dimensions.** The size and dimension of driveways shall conform to the standards indicated in the following table.

LAND USE	REQUIRED WIDTH (FT)	
	MIN	MAX
<i>Single-, Two-, or Multi-Family, up to 4 Units</i>	<b>10 ft</b>	<b>1/3 of Lot Frontage OR 20 ft<sup>1</sup></b>
<i>Multi-Family, over 4 Units</i>	<b>12 ft</b>	<b>20 ft</b>
<i>Nonresidential, One-Way Access</i>	<b>10 ft</b>	<b>16 ft</b>
<i>Nonresidential, Two-Way Access</i>	<b>18 ft</b>	<b>24 ft</b>

**NOTE:** (1) Whichever is less.

- F. Conformance with Local and State Regulations.**

1. All curbcuts and street openings shall conform to the requirements of Chapter 183 (Streets and Sidewalks) of the Town of Tonawanda Code and the Town's Design and Construction Standards.
2. All exit or entrance drives connecting a parking and loading spaces to the street shall be approved by the Town of Tonawanda Engineer, Highway Superintendent, and Director of Planning and Development, as well as the Erie County and New York State Departments of Transportation, where involved.
3. Reference should be made to the New York State Department of Transportation Access Management Guidelines and regulations to determine the most appropriate access management strategy, including shared access and spacing of curbcuts.

# Article 31. Landscaping, Screening & Open Space

## §215-31.1

### PURPOSE & INTENT

---

- A. Purpose.** The Town of Tonawanda recognizes the value of trees and landscaping and that the preservation and enhancement of these resources is necessary to protect the health, safety and welfare of Town residents. Landscaping is considered an integral part of site design, offering shade and habitat, impeding soil erosion, providing water absorption and retention to inhibit excess runoff and flooding, enhancing air quality, offering a natural barrier to noise and enhancing property values and providing scenic beauty. Landscaping emphasis shall be placed on providing features that enhance the overall aesthetics of development and the character of the Town of Tonawanda.
- B. Intent.** The standards located within this Article are intended to:
1. Establish minimum standards and criteria for landscaping for multi-family and nonresidential development in the Town, including parking areas.
  2. Dissuade the unnecessary clearing and disturbing of land to preserve the natural and existing growth of flora.
  3. Ensure the replacement of removed flora, or to establish new flora, that is indigenous to the Western New York region.
  4. Reduce the effects of wind and air turbulence, noise and the glare of automobile lights.
  5. Provide unpaved areas for the absorption of stormwater runoff and prevent soil erosion and avoid the blighted appearance of parking areas.
  6. Conserve and stabilize property values, preserve a healthful environment, and facilitate the creation of a convenient, attractive, and harmonious community environment.
- C. Redevelopment.** These regulations are further intended to guide redevelopment of existing properties and new facilities in a manner compatible with the future development vision of the Town of Tonawanda. As redevelopment and investment takes place, emphasis should be placed on improving the aesthetics of the site and surrounding area, especially as it relates to commercial corridors and views along the waterfront.

## §215-31.2

### APPLICABILITY

---

- A. Uses Subject to Regulation.** All nonresidential, mixed-use, and multi-family developments shall meet the requirements of this Article. Single-, two-, and multi-family properties up to four units shall be exempt from these provisions.

- B. Development Plan Review.** The requirements of this Article shall be applied and approved through development plan review as provided for by Article 42.
- C. Review Body(s).** The terms "review body" or "reviewing body" shall mean the board, committee, commission, or other agent with development plan review authority as duly designated by Article 42.
- D. New Construction.** New construction and infill development shall be in conformance with all requirements of this Article, unless otherwise provided herein.
- E. Existing Sites.** Improvements to existing developed sites shall follow the regulations of this Article to the greatest extent practicable. In the case of nonconformities, Subsection G shall apply.
- F. Substantial Improvements.** Where the total cost of proposed improvements to an existing site are 75% or more of the property's assessed value, all improvements shall be in full compliance with this Article.
- G. Nonconformity.** A building or site not in conformance with this Article may not be required to bring the entirety of such structure into conformance, if, in the opinion of the reviewing body, the proposed improvements to the property do not increase the level of nonconformity and are otherwise consistent with the intent of this Article.
- H. Property Owner Assistance.** Owners of existing sites are strongly encouraged to consult with Town Staff and/or all applicable review bodies for assistance in following these design guidelines prior to making exterior repairs, renovations, restorations, and alterations to their buildings.

### §215-31.3

### LANDSCAPE PLAN REQUIREMENTS

---

- A. Landscape Plan.** A landscape plan shall be required as part of the development plan review process, where applicable. Where determined to be necessary by the reviewing body, the landscape plan may be required to be prepared, signed and stamped by a professional, NYS licensed, or registered landscape architect, certified nurseryman, landscape designer, civil engineer, or architect.
- B. Plan Specifications.** The landscape plan shall be drawn to scale, and include the locations and dimensions of the following, as applicable:
  - 1. Existing and proposed structures and uses;
  - 2. All parking and loading areas;
  - 3. All vehicular, pedestrian, and bicyclist connections;
  - 4. Refuse disposal areas and dumpsters;
  - 5. Outdoor assembly, seating, and storage areas;
  - 6. Existing and proposed trees, shrubs, and plantings, including those that are to be removed;
  - 7. Drainage patterns and stormwater management facilities; and
  - 8. Provisions for visual and noise screening.



- C. Proposed Planting Summary.** Landscape materials to be used on the site shall be identified in a planting schedule or species list to be included on the landscape plan with the following information:
1. Type, common, and botanical names;
  2. Size and quantity; and
  3. Pit or bed treatment.

## §215-31.4

### PLANT MATERIAL REQUIREMENTS

---

- A. Mixing of Species.** Landscape plans should include a variety of trees, shrubs, and ornamental planting (annuals and perennials) as part of the site design. The mixing of trees and shrubs helps to avoid a uniform, unnatural appearance, and to protect against extreme loss due to disease or infestation.
- B. Appropriateness of Species.**
1. All plant material, including grasses, shall be compatible with soil conditions on-site and the regional climate and in accordance with those appropriate for the Town of Tonawanda's Plant Hardiness Zone (Zone 6a) as defined by the United States Department of Agriculture, including any amendments thereto.
  2. Native species shall be utilized to the greatest extent possible.
  3. Plastic or other artificial plantings or vegetation are not permitted.
  4. Under no circumstance shall any site include plant material that is considered by the NYS Department of Environmental Conservation to be a prohibited and regulated invasive species per NYS Law 6 CRR-NY V C 575, including any amendments thereto.
- C. Suggested Species.** The Town shall maintain a list of suggested tree species by plant type. However, this shall not preclude the use of other appropriate plant material in accordance with Subsection B above.

**D. Minimum Tree Specifications.** All trees shall be species having:

1. A minimum caliper of three inches measured two feet above ground level at the time of planting,
2. An average crown spread of greater than 15 feet at maturity and trunks which can be maintained in a clean condition, free of branches from grade to generally 12 feet above grade along principal street edges and 10 feet above grade elsewhere.
3. Trees having an average mature spread of less than 15 feet may be substituted by grouping the same to create the equivalent of a 15-foot crown.

**E. Minimum Shrub and Hedge Specifications.**

1. Shrubs shall be a minimum of two feet in height when measured immediately after planting.
2. Hedges shall be planted and maintained to form a continuous visual screen within two years after time of planting.

**§215-31.5****GENERAL STANDARDS & CRITERIA****A. Minimum Areas of Open Space and Landscaping.** The provision of open space and landscaped areas shall conform to the following:

1. Areas of open space shall be provided at the rate required by the district in which the lot is located (see Part 2, District and Use Regulations).
2. Landscaping shall be provided at a rate of at least 5% on the owned site and 10% on the total property.
3. Areas of open space in the right-of-way may count toward the provision of landscaping and open space on the property to the extent permitted by the reviewing body.

**B. Existing Vegetation.** Existing vegetation and trees (of all sizes and stages of maturity) shall be maintained, wherever possible.**C. Landscape Design.**

1. Appropriate shrub and tree plant materials shall be arranged in rows or clusters, and designed as buffers, screens or hedges in a manner that:
  - a. Gives attractive definition to the street edges or other areas of a lot.
  - b. Screens a lot along its lot lines with adjacent properties.
  - c. Screens utility buildings, refuse collection areas, storage areas, cooling systems or other similar structures, and other similar installations and features.
  - d. Provides landscaped islands or planted sub-areas which punctuate otherwise developed internal portions of a site, in conjunction with appropriate combinations of decorative fences, walls and berms.
2. The arrangement and spatial location of landscaped areas shall be designed as an integral part of the site development and disbursed throughout the site, and not just located around the perimeter.

3. Plantings should be designed to stage blooms and have color throughout the growing season.
  4. Effective use of earth berms and existing topography is also encouraged as a component of the landscaping plan.
  5. Ornamental lighting and street furnishings may be incorporated within landscaped areas with development plan review approval.
- D. Snow Removal and Storage.** Provisions for snow removal and snow storage must not adversely impact landscaped areas. Any area damaged as the result of snow removal or storage activities must be fully restored in accordance with the approved landscaping plan within the next planting season.

### §215-31.6

#### LAWN AREA

- A. Grass areas may be sodded, plugged, sprigged, hydro-mulched, or seeded except that solid sod shall be used in swales or other areas subject to erosion.
- B. In areas where other than solid sod or grass seed is used, over-seeding shall be sown for immediate effect and protection until coverage is otherwise achieved.
- C. Replacement or over-seeding mixes shall match or compliment the original installation.
- D. Grass areas shall also provide continuous, uniform, and consistent coverage.

### §215-31.7

#### BUILDING FOUNDATION LANDSCAPING

- A. A mix of landscape plantings shall be installed around all building foundations to the satisfaction of the reviewing body.
- B. Plant material should be placed intermittently against long expanses of buildings walls, fences, and other barriers to soften the effect and to help break-up walls with little to no architectural detail.
- C. Ornamental plant material, such as flowering trees and shrubs, perennials, and ground covers are encouraged.
- D. Plantings should decrease in size and increase in detail, color, and variety near entryways into buildings.

### §215-31.8

#### PERIMETER LANDSCAPING & TREES

- A. **Right-of-Way Areas.** Areas between street curbing or the edge of rights-of-way and sidewalks on Town-owned streets shall be landscaped. Town, Erie County and New York State rights-of-way may be improved under the following conditions:
  1. Where the existing space between the curblines and sidewalk is less than three feet, that area may be improved with stamped colored concrete, brick pavers, or other approved material.
  2. Where the existing space between the curblines and sidewalk is greater than three feet, that area shall be improved with landscaping in the form of street trees or grass or other appropriate approved natural materials.

3. Where plans for improvements to the public space include adding or replacing sidewalk, the area between curb and sidewalk shall be landscaped to provide a minimum five-foot snow storage area.
  4. Improvements to the public space shall be approved by the right-of-way owner prior to the Town completing site plan review.
- B. Tree Spacing.** Trees shall be planted at a spacing pattern of at least one tree every 30 linear feet along site edges adjoining principal streets. This requirement may be modified to allow for grouping where deemed appropriate by the reviewing body.
- C. Sight Obstructions.**
1. Landscaping patterns along street right-of-way lines shall be consistent with the unobstructed view corridor standards established by § 215-25.1 (Sight Obstructions).
  2. Shrubs and similar materials shall generally not be higher than three feet above the adjacent street grade and street trees shall have branches generally no lower than 12 feet above the adjacent street grade.
- D. Screening from Residential.**
1. Where any nonresidential or mixed-use property immediately abuts a residential property or use shall install a combination of the following for the purposes of buffering and screening (**see Figure 31.1**).
    - a. Decorative, opaque fencing, hedges, or other live vegetative barrier at least five feet in height.
    - b. Tree plantings spaced a minimum of 25 feet center-to-center or shrub plantings located a minimum of five feet center-to-center.
  2. Parking and loading areas shall be screened from residential in accordance with §215-31.9 A.

**FIGURE 31.1 Screening from Residential**

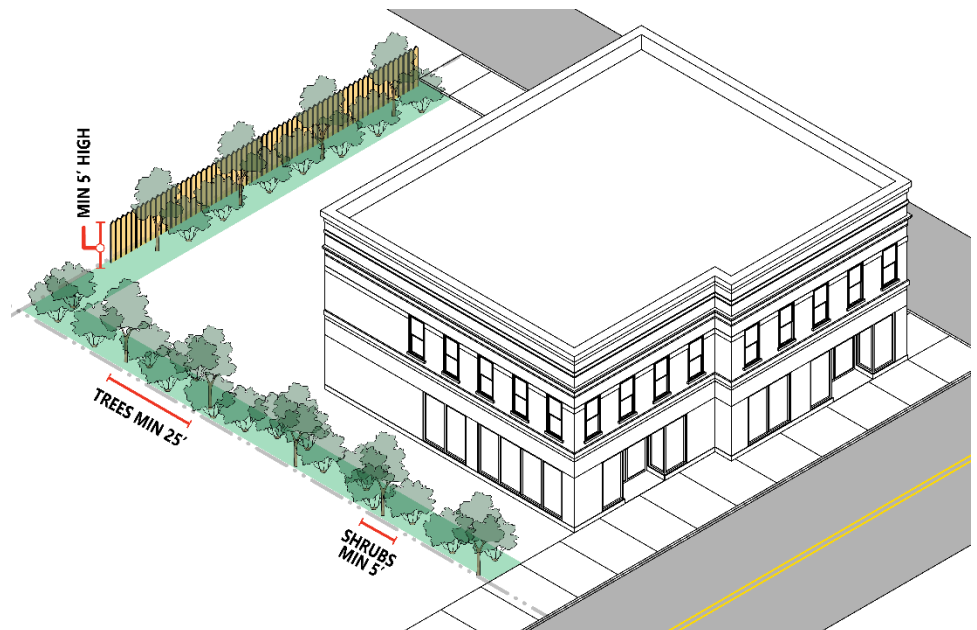

- E. Screening Along Street Frontage.** In the MU-I and GI Districts, nonresidential uses shall provide a landscaped buffer of at least 20 feet in width along all street frontages.

## §215-31.9

### OFF-STREET PARKING & LOADING AREAS

---

- A. Screening from Residential.** Off-street parking and loading areas abutting a residential district or property line shall conform to the following:
1. Where the minimum setback requirements are met, the perimeter shall be landscaped with ground cover, low shrubs or flowering plants, and shade trees planted at intervals of not more than 25 feet.
  2. Where the minimum setback requirements are unable to be met due to the physical constraints of the site, a solid wall or fence at least five feet in height shall be required in addition to the above.
  3. The reviewing body may waive or modify these requirements as deemed necessary during development plan review.
- B. Screening at Street Frontage.** Off-street parking areas located along a primary street frontage shall be screened with a minimum two-foot decorative knee-wall. The location of such wall shall be subject to reviewing body approval.

FIGURE 31.2 Parking Lot Knee Wall

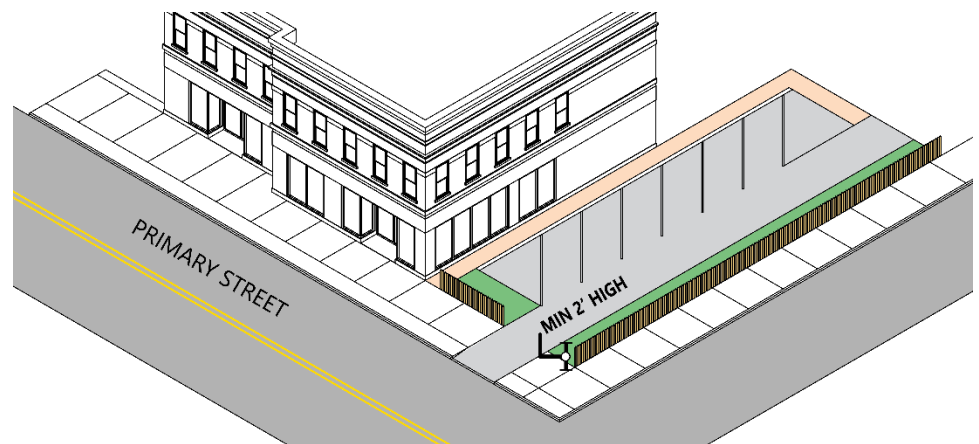

**C. Landscaped Islands and Medians.** Parking areas containing 10 or more spaces shall include landscaped islands and/or medians in accordance with the following:

1. Landscaped islands should be utilized in parking areas to separate parking stalls into groupings of not more than 20 spaces between islands **(see Figure 31.3)**.
2. Parking areas should be broken up into “rooms” of no more than 40 spaces, separated by landscaped medians or pedestrian accessways **(see Figure 31.3)**.
3. The dimensions of all islands and medians should be a minimum of eight feet wide at the shortest side to protect plant materials and ensure proper growth **(see Figure 31.3)**.
4. Each island and median shall include at least one tree. Low shrubs and ground covers will be required in the remainder of the area **(see Figure 31.3)**.
5. Trees shall be provided at a rate of one shade tree per eight spaces. Large and medium shade trees (no less than eight feet in height at maturity) are recommended. Due to heat and drought stress and vision clearances, ornamental and evergreen trees are not recommended in parking areas.
6. Islands and medians shall be protected with concrete curbing.

FIGURE 31.3 Parking Area Design & Landscaping

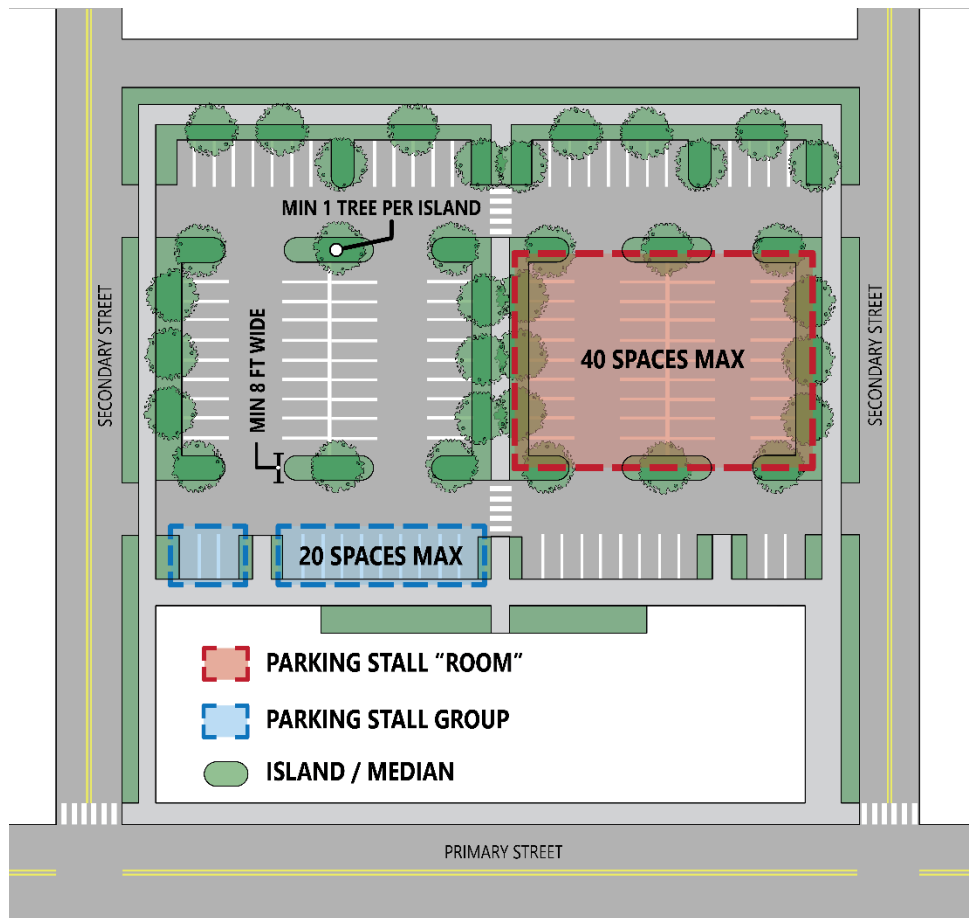

D. **Existing Vegetation Credit.** The above-mentioned standards may be amended as part of development plan review to allow credit for existing, retained plant material if such an adjustment is in keeping with the intent of these standards.

§215-31.10

DUMPSTER SCREENING

- A. **Location.** No dumpster shall be located near or adjacent to a primary roadway or otherwise visible from the road.
- B. **Screening.** Dumpsters shall be screened from public view in accordance with the following:
  1. Screening shall include a combination of landscaping and decorative opaque fencing or similar enclosures.
  2. Enclosures must be equal to or taller than the dumpster being screened.
- C. **Use.** Dumpsters shall be secured and kept closed when not in use.
- D. **Exceptions.** Where conformance with the above may be infeasible due to site constraints, the requirements may be waived or modified by the reviewing body. In such cases, the waiver or modification of requirements should still ensure the greatest level of compliance with the spirit and intent of this section.

**§215-31.11****MECHANICAL EQUIPMENT SCREENING**

---

- A. Ground Level Equipment.** Mechanical equipment located at ground level must be effectively screened with vegetation, low berms, fencing, or others measures that are equal to or taller than the equipment being screened.
- B. Rooftop Mounted Equipment.**
  - 1. Rooftop equipment should be so grouped and located to minimize visibility from the ground to the greatest extent practicable.
  - 2. Where visible from the public right-of-way or abutting residential uses, architectural screening in the form of a parapet wall or other design feature shall be utilized.
  - 3. Equipment placed on the building roof may be permitted above the maximum height specified, provided that such mechanical equipment is set back a minimum of 15 feet from any exterior walls and does not exceed 10 feet in height above the finished roof line of the building upon which it is installed.

**§215-31.12****LANDSCAPING & TREE MAINTENANCE**

---

- A.** All landscaping and screening shall be maintained according to the provisions of this Article and approved landscape plan, or as amended by an approved development plan revision.
- B.** The property owner, or his designated agent, shall be responsible for the proper care and maintenance and replacement, if necessary, of all landscape materials in a healthy and growing condition.
- C.** Maintenance shall include, but not be limited to; watering, weeding, mowing (including trimming at the base of fencing), fertilizing, mulching, proper pruning, and removal and replacement of dead or diseased trees and shrubs on a regular basis.
- D.** All landscaping and plant material that is missing, dead, decaying, or injured as of September 30th shall be replaced by June 30th of the following year at the property owner's expense. The replacement shall be of the same species and size unless otherwise approved as part of development plan review.
- E.** Irrigation systems shall be designed to minimize spray on buildings, neighboring properties, roads or sidewalks; maintained in proper operating condition and conserve water to the greatest extent feasible.
- F.** Improper maintenance shall be determined through periodic inspection by the Code Enforcement Officer. The Code Enforcement Officer may require a review and status report of plantings by a professional landscaper, arborist, or engineer. All reasonable costs for review and determination shall be at the property owner's expense.

**§215-31.13****OPEN SPACE & GREEN SPACE**

---

- A. Preservation of Existing.** Open spaces, green spaces, public preserves, parklands, vegetative buffers, and other such natural areas shall be retained and established as required by this Chapter.
- B. Minimum Open Space Areas.** Minimum areas of open space and greenspace, including any landscaped areas, shall be provided at the rate required by the



district in which the property is located (see Part 2, District and Use Regulations). Open space and green space areas need not be contiguous but shall be of a useable size and area deemed appropriate by the reviewing body.

- C. Stormwater Facilities as Open Space.** Stormwater management facilities and green infrastructure, such as detention ponds or bioswales, shall not be considered open space for the purposes of this Chapter unless they are designed to be a multi-functional, productive, working landscape that serves local environmental, aesthetic, and/or recreational benefits.
- D. Passive Recreation Space.**
1. Open space and greenspace areas may be used for passive recreation activities, such as walking trails, picnic areas, gardens, preserves, or similar uses, provided the lands are preserved in their natural state to the greatest extent practicable.
  2. Buffer areas may be used for passive recreation activities and may contain bicycle or pedestrian pathways, provided such activities do not compromise the primary buffering function of such areas.
- E. Additional Designation of Open Space.** The reviewing body, as part of development plan review, may require the reservation or creation of open space more than the minimum requirements herein, provided such designation is determined to be:
1. Consistent with the Town's adopted plans and studies with respect to environmental conservation and improving public use of and access to green spaces, recreational areas, trails, and the waterfront;
  2. Necessary for the protection and preservation of natural resources, local habitats, wildlife, and native species, woodlots, and/or wetlands; and
  3. A significant benefit to the health, safety, and general welfare of the public, relative to the burden placed upon the property owner and/or developer in preserving, maintaining, and/or programming such areas.
- F. Two Mile Creek and Rattlesnake Creek Buffers.**
1. A minimum of 50 feet on either side of Rattlesnake Creek, Two Mile Creek, or their tributaries shall be maintained in its natural state or as landscaped open space.
  2. The setback distance shall be measured from the average adjacent high-water line of the water body.
  3. The protection of natural drainage elements within the project area is encouraged.
  4. Developments are encouraged to provide public access along any drainage element or within the fifty-foot buffer area where it is appropriate or desired to integrate the preservation of the drainage features into the open space element of the project design and accommodate trails.

# Article 32. Building & Site Design Standards

## §215-32.1

### PURPOSE & INTENT

---

- A. Purpose.** The purpose of this Article is to improve the overall character and image of the Town of Tonawanda through the application of building and site design standards to future development and investment. These regulations are further intended to guide redevelopment of existing properties and new facilities in a manner compatible with the future development vision of the Town of Tonawanda. As development takes place, emphasis should be placed on improving the aesthetics of the site and surrounding area, fostering high-quality investment, and promoting the Town as an attractive place for people to live, work, shop, and socialize.
- B. Objectives.** All nonresidential, mixed-use, and multi-family buildings and structures within in the Town shall be designed to achieve the following objectives:
1. Improve the ambiance and visual quality of the Town's commercial, industrial, waterfront, and mixed-use areas;
  2. Promote diversity in architectural design, variations in building footprints, and visually interesting façades, while also creating a cohesive aesthetic between buildings on the same site and/or streetscape;
  3. Reflect the appropriate and desired building scale and character of the surrounding neighborhood, activity center, and/or corridor;
  4. Utilize elements, details, styles and architectural features for buildings, sites, and public spaces that enhance the visual appeal of the surrounding area and foster a sense of place;
  5. Utilize high-quality building materials and avoid prototypical corporate or franchise style architecture to ensure longevity in the life and use of buildings and structures; and
  6. Encourage the development of buildings consistent with the goals of the Leadership in Energy and Environmental Design (LEED) program.

## §215-32.2

### APPLICABILITY

---

- A. Uses Subject to Regulation.** These design standards shall apply to all existing, altered, or newly constructed buildings, sites, and structures of the following uses and developments:
1. Nonresidential uses, including industrial uses;
  2. Mixed-uses, whether located on the same site or within the same structure; and
  3. Multi-family dwellings over four units.
- B. Development Plan Review.** The requirements of this Article shall be applied and approved through development plan review as provided for by Article 42.

- C. Review Body(s).** The terms “review body” or “reviewing body” shall mean the board, committee, commission, or other agent with development plan review authority as duly designated by Article 42.
- D. New Construction.** New construction and infill development shall be in conformance with all requirements of this Article, unless otherwise provided herein.
- E. Existing Buildings and Sites.** Improvements to existing buildings and sites shall follow the regulations of this Article to the greatest extent practicable. In the case of nonconformities, Subsection G shall apply.
- F. Substantial Improvements.** Where the total cost of proposed improvements to an existing building and/or site are 75% or more of the property's assessed value, all improvements shall be in full compliance with this Article.
- G. Nonconformity.** A building or site not in conformance with this Article may not be required to bring the entirety of such structure into conformance, if, in the opinion of the reviewing body, the proposed improvements to the property do not increase the level of nonconformity and are otherwise consistent with the intent of this Article.
- H. Property Owner Assistance.** Owners of existing buildings are strongly encouraged to consult with Town Staff and/or all applicable review bodies for assistance in following these design guidelines prior to making exterior repairs, renovations, restorations, and alterations to their buildings.

### §215-32.3

### BUILDING PLACEMENT & ORIENTATION

- A. Context.** Placement refers to how a building is situated on the lot. Orientation refers to the location of a building's main axis, or primary façade. Building placement and orientation is a crucial part of the interface of private building façades with public thoroughfares, which shape a compact, walkable public realm.
- B. Building Placement.** The placement of buildings shall follow the minimum and maximum front setback requirements of this Chapter. Relief from this provision may be provided for appropriate architectural elements and pedestrian amenities, such as recessed entries or chamfered corners, as deemed appropriate by the reviewing body.
- C. Building Orientation.**
  1. The primary façade(s) shall be oriented to the street and waterfront, where applicable.
  2. Where multiple buildings are located on the same lot, the primary façades shall be oriented to foster a campus style environment as deemed appropriate by the reviewing body.
- D. Accessibility.** All buildings shall be accessible to emergency vehicles.
- E. Integration and Arrangement.**
  1. All buildings in the plan shall be integrated with each other and with adjacent buildings and shall have convenient access to and from adjacent uses.
  2. All buildings shall be arranged to avoid undue exposure to concentrated loading or parking facilities, wherever possible, and shall be oriented to preserve visual and auditory privacy between adjacent buildings.

## §215-32.4

## BUILDING MASSING &amp; FORM

- A. Context.** Massing and form refer to the volume and shape of a building. Buildings should provide visual interest that engages pedestrians and others to promote activity and business vitality.
- B. Building Massing.**
1. Buildings should be taller than they are wide. Buildings which are "squat" in proportion, or which have very strong horizontal elements that dominate the façade, are discouraged.
  2. Primary buildings in the mixed-use districts (MU-N, MU-GC, MU-W, and MU-I) shall appear to be a minimum of 1 and ½ stories in height.
  3. All buildings shall exhibit a clearly defined base, mid-section, and crown. This can be accomplished using a combination of architectural details, materials, textures, and colors (see Figures 32.1 and 32.2).

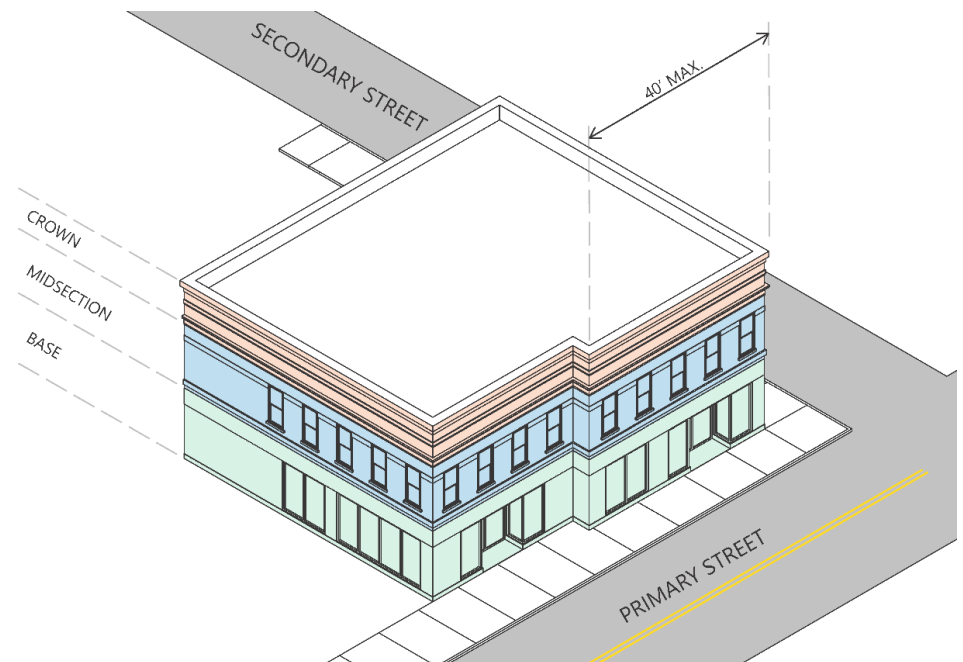
**FIGURE 32.1 Façade Articulation (MU-GC, MU-W, MU-I)**

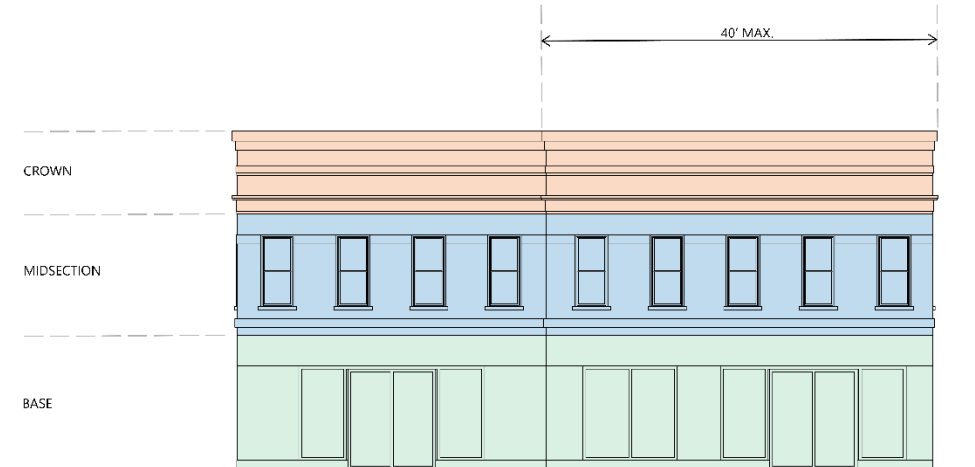

**FIGURE 32.2 Façade Articulation (MU-N)**

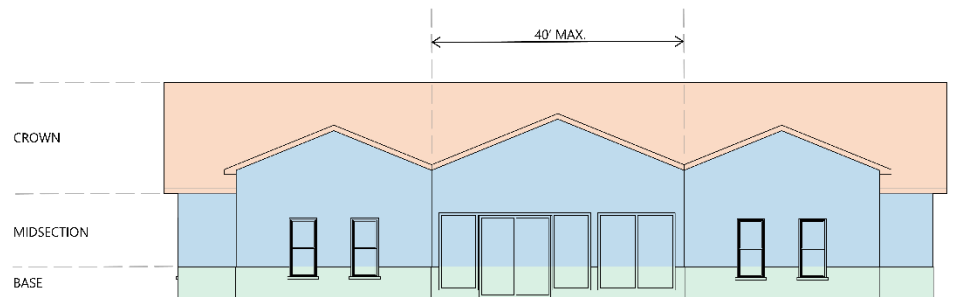
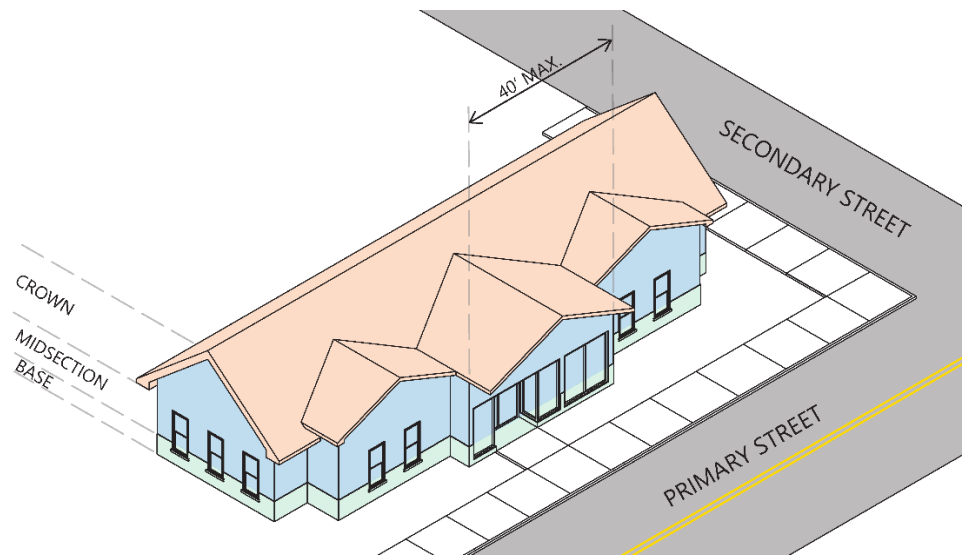

4. A single, large, dominant building mass shall be avoided. No façade shall have a blank, uninterrupted length exceeding 40 feet without including architectural features such as columns, pilasters, piers, or changes in plane, in texture or masonry pattern, storefronts and entry treatments, or

equivalent design element that subdivides the wall into pedestrian-scaled proportions (see Figures 32.1 and 32.2).

### C. Building Form.

1. Buildings designed to advertise or promote a uniform corporate image in a manner that may render the building undesirable or unable to reasonably accommodate future uses shall be prohibited.
2. Buildings situated at street corners shall "wrap" the corner by continuing certain façade elements (such as the cornice, roofline treatments, or horizontal accent bands) on all street elevations (see Figure 32.3).
3. Buildings of two or more stories shall have a transition line. A transition line is a horizontal architectural element, such as a cornice, balcony or change in material, which spans the full width of the façade, and creates a distinction between the first and second stories. Transition lines shall be designed in proportion to the overall height and width of the building (see Figure 32.3).

**FIGURE 32.3** Continuous Façade Elements

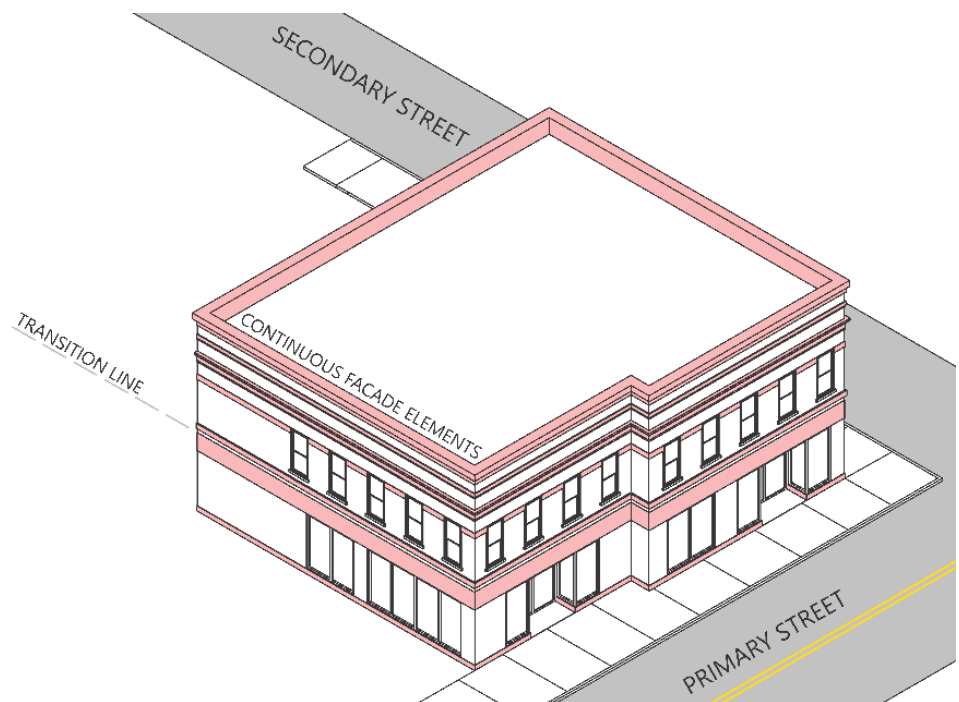

## §215-32.5

### BUILDING FAÇADES & FENESTRATION

#### A. Context.

1. A building façade serves as the interface between the public realm and the interior space of the building and should be compatible with the character and context of the surrounding area. Proper façade composition creates visual interest and adds character to a façade, providing visibility into the building interior, particularly for retail uses,

contributing to the pedestrian, bicyclist, and motorist experience throughout the Town.

2. Fenestration refers to the area of the façade or building exterior covered with openings, in particular windows and doors, how transparent the enclosing glass in the openings is, and how the openings are arranged and/or relate to each other with respect to size, depth, location, etc.

**B. General Façade Design.**

1. Buildings should employ four-sided architecture design practices, extending and relating architectural detailing and design elements across all façades.
2. The same exterior treatment provided to the primary façade shall also be provided to any side and rear wall facing a public right-of-way or residential use.
3. For the purposes of this Article, buildings that are located on a street corner are considered to have two primary façades.
4. Façade elements such as windows and bays shall be of a consistent proportion to each other.
5. The use of depth is encouraged to highlight façade openings such as windows to create a three-dimensional relief which produces shadows.

**C. First Floor.** Includes the area of façade below the roofline for single-story structures, or the transition line for two or more story structures.

1. The first floor of any building should be between 12 and 15 feet in height.
2. The first floor of a structure shall include vertical elements dividing the building into "bays." Each bay should contain a window or entrance door.
3. The first-floor levels of a façade shall provide the highest amount of façade openings, articulation, and transparency.

**D. Upper Floors.** Includes all façade area above the transition line.

1. The spacing and rhythm of upper-floor openings shall match that of the major entrance and design elements on the first floor.
2. Upper-floor openings shall be residential in size, proportion, and character.

**E. Windows and Doors.**

1. All primary façades shall observe the transparency requirements by use and zoning district in the following table.

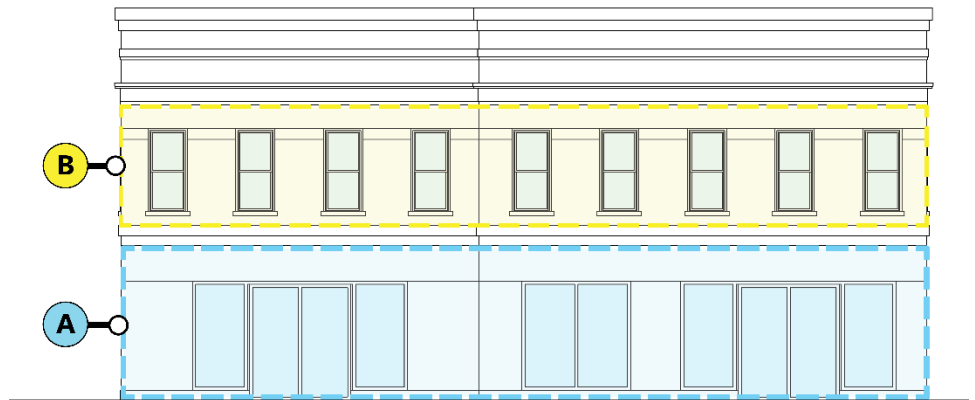

BUILDING / USE	R-1, R-2, MR	MU-N	MU-GC, MU-W	MU-I, GI
<b>MIN Transparency – First Floor (A)</b>				
<i>Commercial/Mixed Use</i>	25%	35%	50%	35%
<i>Other</i>	25%	25%	35%	35%
<b>MIN Transparency – Upper Floors (B)</b>				
<i>All Buildings/Uses</i>	20%	20%	35%	-
<b>MAX Transparency – Total Façade Area (A+B)</b>				
<i>All Buildings/Uses</i>	65%	75%	85%	75%

**NOTE:** Transparency shall be measured as the percentage of the primary wall area per floor.

2. Doors that are comprised of an area of at least 30% transparent glass shall be used for building entrances on the primary façade. Opaque doors may be used for doorways providing access to upper floors.
3. The use of opaque, mirrored, or tinted glass with less than 50% light transmittance is prohibited. If screening is necessary, interior blinds or curtains are encouraged.

**F. Storefronts and Entrances.**

1. Primary entrances shall face the street and be so located to afford direct access from the sidewalk, where applicable.
2. Where parking areas are located behind the building, secondary entrances should be provided at the rear or side of the building to offer direct access.
3. Upper floor entrances shall be distinguished from entrances for first floor uses.
4. Corner buildings may have two separate entry points or a single-entry point at the corner.
5. Storefront construction should be recessed enough at the point of entry to allow the door to swing out without obstructing the sidewalk, where applicable.



6. The sill of storefront windows should be no higher than three feet above grade.

**G. Awnings and Canopies.**

1. Awnings or canopies may be permitted over entrances, storefronts, large first-floor windows, and upper-floor windows.
2. Awnings and canopies shall be designed to fit the window, door, or storefront openings that they are intended to cover. Placement should not conceal architectural features.
3. The use of reflective, neon, translucent, wood, metal, plastic, fiberglass, aluminum, or stock metal materials is prohibited.
4. Awnings and canopies shall be capable of withstanding both high winds and winter snow loads.
5. Street-level awnings and canopies shall be mounted so that the bottommost edge is no less than seven feet above grade.
6. Awnings and canopies shall not project more than seven feet from the building façade.

## §215-32.6

### ROOF STYLES & TREATMENTS

---

- A. Context.** A roofline is an architectural element, such as a cornice, parapet, or change in material, plane, or design, which creates a distinction between the top of the building and the lower floors.
- B. Roof Design.**
1. All structures shall have a distinct, visible roofline.
  2. Building rooflines should be varied to highlight entrances and bays and otherwise contribute to the visual interest of the building.
  3. Rooflines shall be designed in proportion to the overall height and width of the building.
  4. Flat roofs shall slope to the back of the building to provide proper drainage and shall include a cornice element.
  5. Peaked or gable roofs shall be consistent with the placement, size, and patterns of nearby or adjacent structures, where applicable.
  6. Mechanical equipment that is located on the rooftop shall be effectively screened with parapet walls, decorative fencing and/or gables to eliminate views from the ground level.
- C. Sustainable Roof Treatments.**
1. Roofing materials that reflect sunlight (e.g. lighter colors) or incorporate vegetated roofing are encouraged. Lighter colors decrease heating and cooling needs, while green roofs reduce stormwater run-off.
  2. Where green roofs are proposed, the reviewing body may deduct a portion of the green roof building from the lot coverage calculations up to 75% of the green roof footprint.

3. The use of alternative energy materials and systems, such as solar panels or shingles, is encouraged. Their installation shall be incorporated into the design of the building so as not to detract from the architectural style and detailing.
4. Where feasible, roof-mounted alternative energy equipment shall be located so as not to be visible from the public right-of-way.

## §215-32.7

### MATERIALS & COLOR

---

#### A. Allowable Materials.

1. Building façades shall be constructed of durable materials such as brick, stone, finish masonry, or fiber cement (panels, siding, and trim boards) or finished wood, or their equivalent or better. The most stringent quality standards will be applied to buildings in locations most visible to people in public spaces.
2. In proposing other exterior building materials, the applicant must show that the material is appropriate to the use proposed and will not significantly impact the overall visual quality of the environment.
3. The use of modern materials or design may be permitted at the discretion of the reviewing body. This may include, but is not limited to, the use of metal for decorative features.

#### B. Variety of Colors and Materials.

1. No less than two and no more than three building materials or colors (excluding trim) shall be used on any one façade of a building.
2. A single material or color should be used as the dominant theme in the façade, with secondary materials and colors used to highlight and accent the design.
3. Changes in materials shall occur at inside corners. Material changes at the outside corners or in a plane shall be prohibited, unless otherwise approved by the reviewing body.

#### C. Metal Buildings.

1. No building or structure may be constructed 100% of metal materials, except for accessory structures which may be of pole barn style construction.
2. The finishing of pole barn style accessory structures shall reflect the character and design of the primary structure on the same lot.

#### D. Prohibited Materials.

1. The use of stucco, vinyl, fiberglass, plastic panels, sheet metal, clear-coated or corrugated aluminum, iron, stainless steel, mirrored glass, concrete block, or smooth concrete is prohibited.
2. Finishes that are intended or designed to reflect light and glare are not permitted in any district.
3. Exterior Insulation and Finish System (EIFS) material may be permitted with review body approval.

- E. **Color.** Florescent, neon, day-glow, primary, pastel, or metallic colors are prohibited.

## §215-32.8

### DESIGN TRANSITIONS BETWEEN NONRESIDENTIAL & RESIDENTIAL USES

- A. **Applicability.** All nonresidential, mixed, and multi-family use structures shall employ similar building and site design standards to ensure compatibility with adjacent residential development. These requirements shall be applied in addition to the design standards and guidelines of this Article and requirements set forth by this Chapter for landscaping, screening, and buffering of uses.
- B. **Requirements.** To the maximum extent practicable, nonresidential, mixed-use, and multi-family developments shall use all the following techniques when adjacent to a residential use.
  - 1. Similar building setback;
  - 2. Similar building height;
  - 3. Similar roof form; and
  - 4. Similar exterior materials.

## §215-32.9

### GENERAL SITE DESIGN STANDARDS

- A. **Natural Topography and Grading.**
  - 1. The design of buildings and the parking facilities shall take advantage of the natural topography of the project site where appropriate.
  - 2. Contour grading, where both the horizontal and vertical slopes are varied to reflect naturally occurring landforms, is preferred.
  - 3. Grading shall be minimized to the extent possible, and all finished grades shall blend with existing off-site grades.
  - 4. Berming as a grading or visual buffer solution shall be avoided along the riverfront to preserve the existing level or gently rolling topography.
- B. **Open Space.**
  - 1. Areas of open space shall be designed as integral parts of the overall site and shall be properly related to existing and proposed buildings, multi-modal connections, and the waterfront, where applicable.
  - 2. All open space areas shall meet the minimum requirements of §215-31.13
- C. **Pedestrian and Bicyclist Accommodations.**
  - 1. Pedestrian connections shall be designed as integral parts of an overall site design and be properly related to existing and proposed buildings. Separated circulation should be provided to the extent practicable.
  - 2. Buildings and vehicular circulation areas shall be arranged so that pedestrians moving between buildings are not unnecessarily exposed to vehicular traffic.
  - 3. Bicycle and walking paths should be parallel to major roadways or driveways and shall form an interconnected network of path facilities within a property or group of properties.

4. Wherever practicable, every effort should be made to interconnect on-site pathways to adjacent parks and trails, including the larger regional network of paths.
- D. ADA Conformance.** All new or reconstructed off-street parking areas must conform to Americans with Disabilities Act standards.

## §215-32.10

### WATERFRONT VIEWSHED PROTECTION

- A. Applicability.** All sites within the Mixed-Use Waterfront (MU-W), Mixed-Use Industrial (MU-I), and General Industrial (GI) Districts shall be developed in such a way as to maximize view opportunities at the river's edge and view corridors throughout the development.
- B. General Requirements.**
1. Site layout and design shall consider view corridors from the Riverwalk and any adjacent public open space.
  2. Important views should be protected and enhanced to the maximum extent practicable.
  3. To ensure visual access to the water, at least 30% of the shoreline shall be contained within view corridors.
  4. The minimum width of a view corridor shall be 25 feet. Satisfaction of this requirement shall be measured by dividing the number of linear feet of river view preserved in a view corridor by the total river view in a single ownership.
  5. No buildings, walls, or other opaque structures shall be permitted within view corridors. Nonopaque structural elements such as gazebos, pergolas, bandshells or open market or festival stalls are permitted within view corridors.
- C. Development Plan Review Materials.** The reviewing body may require the applicant to provide information which will allow an adequate review of the potential impact of the development on the scenic resources of the area.
1. Information that may be requested may include:
    - a. Photographs of all existing scenic vistas at the site.
    - b. Schematic plans and sections clearly showing the impact that development will have on the scenic vistas.
    - c. Elevations or perspective sketches showing the proposed development and its impact on views to the river from surrounding public open space and/or public rights-of-way.
  2. Based on the findings of the visual assessment, the reviewing body may limit the height or length of any proposed structure and may recommend changes in the arrangements of buildings if in its determination the proposed limitations or changes will protect or enhance the visual character.

## §215-32.11

### STORMWATER MANAGEMENT & GREEN INFRASTRUCTURE

- A. Guiding Documents and Regulations.** The below documents serve as the official guides and specifications for stormwater management.

1. New York State Stormwater Management Design Manual (New York State Department of Environmental Conservation).
2. New York State Standards and Specifications for Erosion and Sediment Control (New York State Department of Environmental Conservation).
3. Town of Tonawanda Design and Construction Standards.
4. Chapter 73 (Stormwater Management) of the Town of Tonawanda Code.

**B. Discharge Preferences.**

1. Where technically feasible, stormwater discharges must be directed to sewers according to the following hierarchy of preference:
  - a. Green infrastructure system in accordance with Subsection C.
  - b. Storm sewer and/or storm overflow sewer.
2. Where the stormwater will be released to a storm sewer or storm overflow sewer, the project must meet both the sizing criteria and water quality standards contained in the New York State Stormwater Management Design Manual.

**C. Green Infrastructure.**

1. Where practicable, stormwater management facilities should utilize Green Infrastructure Best Management Practices (BMPs) according to the following hierarchy of preference:
  - a. Conservation of natural areas.
  - b. On-site infiltration practices including, but not limited to, bioretention cells/rain gardens, vegetated swales, filter strips, constructed wetlands and porous pavement.
  - c. Capture and reuse of runoff through low- impact practices including, but not limited to, green roofs, blue roofs, and rain barrels or cisterns.
2. Where on-site green infrastructure BMPs are not feasible for all or a portion of stormwater runoff volume due to factors including, but not limited to, contamination, high groundwater table, shallow bedrock, or poor infiltration rates, or where it can be proven that such practices would cause property or environmental damage, the remaining portion may be treated by another stormwater management practice acceptable to the reviewing body.
3. In cases where on-site BMPs have been determined not to be feasible, the reviewing body may consider the following alternative stormwater management practices to meet water quantity standards, in order of preference:
  - a. Off-site green infrastructure BMPs within the same sub-sewershed;
  - b. Retention through subsurface infiltration or underground storage vaults;
  - c. Detention through underground storage vaults.
4. Where stormwater management performance standards cannot be met due to unique site constraints or any other conditions beyond the control of the applicant, the reviewing body may provide an exemption to the standards of this section.

# Article 33. Exterior Lighting

## §215-33.1

### PURPOSE & INTENT

---

The purpose of this Article is to provide regulations for exterior lighting to achieve the following objectives:

- A. Allow for the provision of exterior lighting as needed for visibility, security and as an accent to architectural and/or landscape features.
- B. Permit the use of exterior lighting that does not exceed the minimum levels specified in the International Dark Sky Association and the Illuminating Engineering Society of North America recommended practices for night-time safety, utility, security, productivity, enjoyment, and commerce.
- C. Minimize adverse offsite impacts of lighting such as light trespass, and obtrusive light.
- D. Curtail light pollution, reduce skyglow and improve the nighttime environment.
- E. Help protect the natural environment from the adverse effects of night lighting from gas or electric sources.
- F. Conserve energy and resources to the greatest extent possible.

## §215-33.2

### APPLICABILITY

---

- A. **Uses Subject to Regulation.** These regulations shall apply to all exterior lighting on any property utilized for the following purposes:
  - 1. Nonresidential uses, including industrial uses;
  - 2. Mixed-uses, whether located on the same site or within the same structure; and
  - 3. Multi-family dwellings over four units.
- B. **Development Plan Review.** No exterior lighting regulated under this Chapter shall be erected without first receiving approval through development plan review in accordance with Article 42.

## §215-33.3

### LIGHTING PLAN

---

Lighting plans shall be submitted to as part of the development plan review process. Lighting plans must be prepared by a lighting professional and shall include:

- A. Location of lights with specifications,
- B. Level of illumination at all property lines and five feet beyond based on all proposed and existing light fixtures.
- C. Lighting cut sheets for each proposed lighting style, including lamp types (Incandescent, Fluorescent, Low- or High-Pressure Sodium, etc.) and wattage for each proposed light source.

- D. Shielding method proposed to cut-off direct light to adjacent properties.
- E. Height of pole and fixture and/or distance above grade for wall-mounted lighting fixtures.

§215-33.4

LIGHTING DESIGN

- A. The use of lighting fixtures compliant with International Dark Sky Association standards is highly encouraged.
- B. Fixtures shall be fully shielded, pointing downward, to minimize skyglow, glare, and light trespass. Luminaries shall be so hooded or shielded that the maximum angle of the cone of direct illumination shall be 60 degrees drawn perpendicular to the ground. Such angle may be increased to 90 degrees if the luminary is less than three feet above ground (See Figure 33.1).
- C. All lighting fixtures shall be shielded and directed so as not to cast an illumination of more than one (1) foot-candle on adjacent nonresidential properties or more than one-tenth (0.1) foot-candle on adjacent residential properties.
- D. Pedestrian-scale lighting shall be provided along major pedestrian paths and along the Niagara River edge.
- E. Pole-mounted fixtures shall not be mounted higher than 18 feet above grade (see Figure 33.1). Such fixtures may exceed 18 feet in height where NYS or Erie County Department of Transportation, or other such transportation authority regulations require.

FIGURE 33.1 Light Fixture Height & Shielding

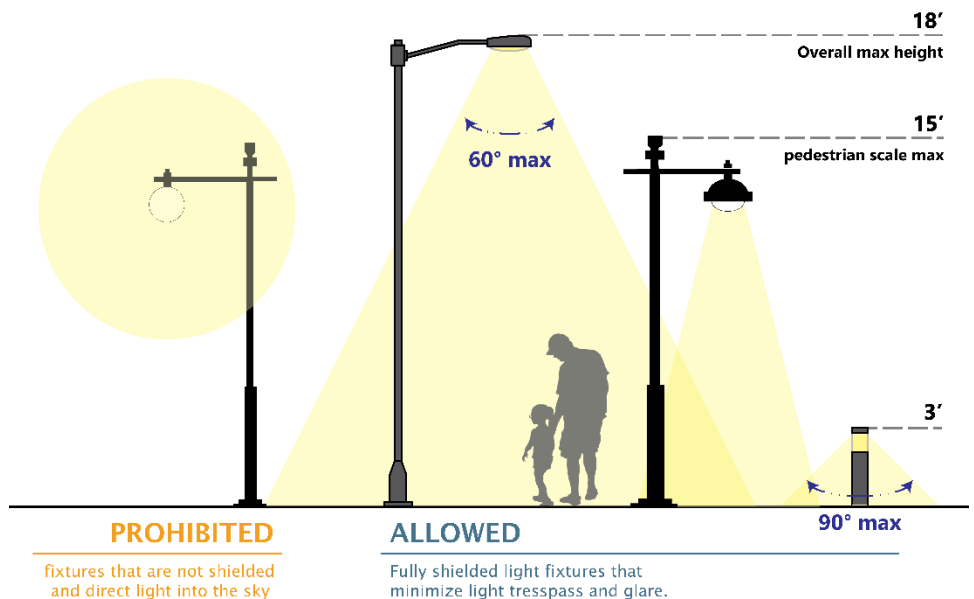

- F. All lighting shall be located and designed as an integral part of the entire project of which it is a part and shall consider the architectural and landscape context of the site.

- G. All wiring for lighting shall be installed underground, where applicable.
- H. The illumination of signs shall also conform to the requirements of Article 34 of this Chapter.

**§215-33.5****INTENSITY OF ILLUMINATION**

---

- A. A banking institution shall be permitted to have light level in excess of the limit in this subsection, but only to the extent necessary to comply with the requirements of Article II-AA of the New York State Banking Law, commonly referred to as the "ATM Safety Act."
- B. Exterior lighting should be illuminated only when needed, such as during business hours or in areas requiring illumination for security purposes. The use of motion activated sensors or reduced lighting after hours is encouraged.
- C. Fixtures shall be no brighter than necessary to illuminate the site and/or area intended. To the extent practicable, lighting fixtures shall be designed and programmed to adjust to ambient lighting conditions (e.g. decreasing the intensity of illumination at nighttime).
- D. Bulb types should be selected to reduce blue light emissions, which may be hazardous to human health and wildlife. The use of white or amber colored lighting is preferred. No lighting shall have a color temperature exceeding 3000 degrees Kelvin.



# Article 34. Signage

## §215-34.1

### PURPOSE

- A. Purpose.** The purpose of this Article is to promote and protect the public health, welfare, and safety by regulating existing and proposed signs which are visible from streets or other public areas or from one property to another. These regulations are designed to balance the development and promotion of business and industry with the provision of signage in a manner that is not a detriment to the public.
- B. Objectives.** The intent of this Article is to achieve the following objectives:
1. Ensure right to free speech as protected under the Constitution;
  2. Establish a clear and impartial process for those seeking to install signs;
  3. Protect property values and create a more attractive economic and business climate;
  4. Preserve the scenic and natural beauty of designated areas;
  5. Reduce the adverse effects of signage on the desired Town character and foster a visually pleasing community environment;
  6. Provide structures and uses with effective means of identification while reducing visual clutter through the prevention of excessive and confusing sign displays;
  7. Reduce visual distractions and obstructions that may impact traffic safety, and reduce hazards that may be caused by signs overhanging or projecting above public rights-of-way; and
  8. Enforce and encourage the objectives and goals of the Town's Comprehensive Plan and other supporting plans and studies.

## §215-34.2

### APPLICABILITY

- A. Signs Under Regulation.** The requirements of this Article shall govern and control the erection, enlargement, expansion, renovation, operation, maintenance, relocation, and removal of all signs within the Town visible from any street, sidewalk, public right-of-way, or public space. This shall include signage provided both on residential and nonresidential properties.
- B. Exempt Signs.** The provisions of this Article shall not apply to safety signs, road signs, historical markers, or highway directional signs erected by municipal or public agencies. Murals and works of art including no commercial message shall also be exempt.
- C. Customary Decorations Permitted.** This Article shall in no event be construed to prohibit the temporary decoration of premises in any district during religious, patriotic or holiday seasons in a customary manner.

## §215-34.3

### SIGN PERMIT REQUIRED

- A. Permit Required.** Apart from the types of signage exempted in §215-34.13 herein, no sign shall hereafter be erected, enlarged, altered, rebuilt, extended, relocated, or used within the Town of Tonawanda, outside of the corporate limits of the Village of Kenmore, unless a permit for such sign is first obtained from the Code Enforcement Officer of the Town of Tonawanda.
- B. Exempt Actions.** The following actions shall not require the issuance of a new sign permit provided such maintenance, changes, or alterations do not in any way alter the physical size, design, or nature of the sign.
  - 1. Normal maintenance and repair of a sign not involving structure changes, including, but not limited to, repainting, repairing, changing of parts, or cleaning.
  - 2. Changes to the content or message of a sign, provided no change is made to the type, size, design, illumination, location, or other physical sign feature. The issuance of a zoning permit shall be required in accordance with Article 41 to ensure compliance with the provisions of this Article.
  - 3. Changes in the sign user, owner, or owner of the property on which the sign is located.
- C. Signs Requiring Permits.** Sign permits are required for certain sign types, depending upon its location, design, or size. The table below indicates permit requirements by sign type.

SIGN TYPE	PERMIT REQUIRED	SIGN REGULATIONS
<i>A-Frame</i>	<b>NO</b>	<b>34.13 (A)</b>
<i>Awning or Canopy</i>	<b>YES</b>	<b>34.18 (A)</b>
<i>Billboard</i>	<b>YES</b>	<b>34.18 (B)</b>
<i>Directional</i>	<b>NO</b>	<b>34.13 (B)</b>
<i>Governmental</i>	<b>NO</b>	<b>34.13 (C)</b>
<i>Ground</i>	<b>YES</b>	<b>34.18 (C)</b>
<i>Incidental</i>	<b>NO</b>	<b>34.13 (B)</b>
<i>Internal</i>	<b>NO</b>	<b>34.13 (D)</b>
<i>Lawn</i>	<b>NO</b>	<b>34.13 (E)</b>
<i>Marquee</i>	<b>YES</b>	<b>34.18 (D)</b>
<i>Neon</i>	<b>NO</b>	<b>34.13 (G)</b>
<i>Pole</i>	<b>YES</b>	<b>34.18 (E)</b>
<i>Projecting</i>	<b>YES</b>	<b>34.18 (F)</b>
<i>Roof</i>	<b>YES</b>	<b>34.18 (G)</b>
<i>Suspended</i>	<b>YES</b>	<b>34.18 (H)</b>
<i>Wall</i>	<b>YES</b>	<b>34.18 (I)</b>
<i>Window</i>	<b>NO</b>	<b>34.18 (J)</b>
<i>Temporary</i>	<b>YES</b>	<b>34.18 (K)</b>

- D. Alteration.** Any sign for which a permit has been issued shall not be modified, relocated, altered, or replaced, unless an amended or new sign permit is obtained from the Code Enforcement Officer.
- E. Expiration.** A sign permit shall expire if the sign for which the permit has been issued is not fully constructed within 180 days from the date of issuance of the sign permit. The Code Enforcement Officer may grant an extension provided

the applicant submits a written request with sufficient reason for the delay in construction.

- F. Revocation.** The Code Enforcement Officer, at any time for a violation of this Article, may issue a notice of violation. A written notice of the violation including all reasons for the violation shall be mailed to the property, building, and/or sign owner. Said violation must be corrected within 30 days of the date of notice, otherwise the sign permit shall be revoked and the sign in question shall be required to be removed.
- G. Variances.** Notwithstanding any other provision of this Article, upon application to the Zoning Board of Appeals, that Board may vary or adopt the strict application of any of the requirements of this Article.

## §215-34.4

### SIGN PERMIT APPLICATIONS

#### A. Application Submitted.

1. Sign permit applications shall be submitted to the Code Enforcement Officer on the appropriate forms provided by the Town of Tonawanda.
2. Incomplete applications will not be processed. The Code Enforcement Officer shall provide written or electronic notice of application deficiencies to applicants. If such deficiencies are not corrected within 30 days of notice, the application will be considered withdrawn.

#### B. Application Requirements.

The following shall be provided in all sign permit applications. The Code Enforcement Officer may require application materials to be prepared by a licensed engineer or sign professional if deemed necessary for adequate review of the proposed sign.

1. Name, address, contact information, and signature of the applicant.
2. Name, address, and signature of the building and/or property owner (if not the applicant), and a statement of consent for the applicant to seek such sign permit.
3. Dimensions and drawings indicating the size, shape, construct, materials, and layout of the proposed sign(s).
4. Site plan and elevations indicating the proposed location and size of the sign(s) drawn to scale.
5. Color illustrations and/or photographs of the proposed sign and sign area.
6. Proposed illumination system, if any, and the type of lighting to be used.
7. Plan for removal of the sign(s) and restoration of the building façade, ground, or other feature to which the sign(s) is proposed to be attached.
8. Any additional site and/or sign information deemed necessary by the Code Enforcement Officer for the proper review of such application.
9. All applicable permit fee(s).

#### C. Review Criteria.

The approval of sign permit applications shall be based upon the following criteria:

1. The sign is not confusing or distracting, nor will it create a traffic hazard or otherwise adversely impact public safety;

2. The sign follows the design guidelines outlined in §215-34.15 to the greatest extent practicable; and
3. The sign is otherwise compliant with this Article and all other applicable local, state, and federal laws and regulations.

## §215-34.5

### REVIEW PROCEDURES

---

#### A. Standard Review Procedures.

1. The Code Enforcement Officer is hereby authorized to review, approve, approve with modifications, or deny a sign application in accordance with this Article.
2. The Code Enforcement Officer may, at their discretion, refer any sign application to the Planning Board for review and issuance of an advisory opinion. Such review may occur at any regularly or specially scheduled Planning Board meeting.
3. The Code Enforcement Officer may utilize the opinion of the Planning Board in the issuance of their decision to approve, approve with modifications, or deny a sign application.
4. Any person aggrieved by a decision for a sign permit by the Code Enforcement Officer may submit an appeal to the Town of Tonawanda Zoning Board of Appeals. Such appeal must be made within 30 days of the date of decision.

#### B. Town Board Review.

Applications for temporary signs that encroach upon, hang over, or are located on public property, except for a-frame signs, shall be subject to review and approval by Town Board under the following procedures.

1. Sign permit applications shall be submitted to the Code Enforcement Officer at least 10 business days prior to the Town Board meeting at which such application is to be considered. Upon receipt of all required information, the Code Enforcement Officer will submit all materials to the Town Board for their review.
2. The Town Board shall review all sign applications received from the Code Enforcement Officer. Such review may occur at any regularly or specially scheduled Town Board meeting.
3. The Town Board may approve, approve with modifications, or deny a sign permit application upon consideration of the application's conformance to the applicable requirements contained in this Article, consistency with the architectural style of the building or structure with which the proposed sign or signs is associated, and all other applicable laws and ordinances.
4. The Town Board may, at their discretion, refer any sign application to the Planning Board for review and issuance of an advisory opinion. Such review may occur at any regularly or specially scheduled Planning Board meeting.
5. The Town Board may utilize the opinion of the Planning Board in the issuance of their decision to approve, approve with modifications, or deny a sign application.

#### C. Development Plan or Special Permit Review.

Developments subject to review and approval under this Chapter may have proposed signage reviewed and

approved as part of the special permit or development plan review process. In the event of such review, all required sign permit application materials shall be provided as part of the special permit or development plan application.

## §215-34.6

## MEASUREMENT

FIGURE 34.1

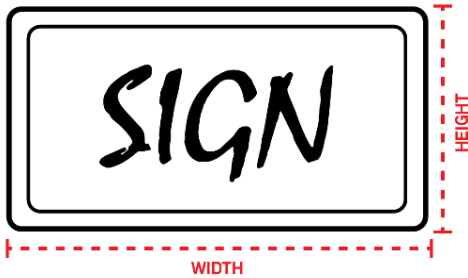
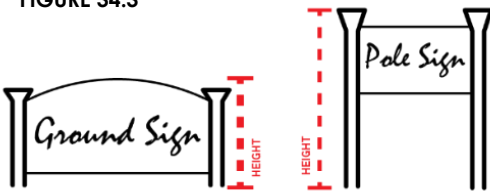

FIGURE 34.2



FIGURE 34.3



## A. Sign Area.

1. One-Sided Sign. The area of a sign shall be computed by means of the smallest square, circle, rectangle, triangle, or geometric combination thereof that will encompass the extreme limits of the writing, representation, emblem, graphic, and/or other display, together with any material, backdrop, or structure on which it is placed. **See Figures 34.1 and 34.2.**
2. Two-Sided Sign. In the case of a two-sided sign only one side of the sign is considered in determining sign area if the sides of the sign are back-to-back or diverge at an angle of 45 degrees or less. No sign shall be permitted to have more than two sides.
3. Structural Support Not Included. The supporting structure or bracing of a sign shall not be computed as part of the sign area unless such supporting structure or bracing is made a part of the message with the inclusion of any text or graphics. If such is the case, a combination of regular geometric shapes which can encompass the area of said text or graphics shall be included as part of the total sign area computation.

## B. Sign Height.

1. Freestanding Sign. The height of a freestanding sign shall be calculated by measuring the vertical distance between the top part of such sign or its structure, whichever is highest, to the elevation of the ground directly beneath the center of the sign. **See Figure 34.3.**
2. Other Signs. The height of an awning, projecting, suspended, wall, or window sign shall be determined by measuring the vertical distance between the top part of the sign face or structure, whichever is highest, to the bottommost edge of the sign face. **See Figures 34.1 and 34.2.**

## §215-34.7

## SAFETY PROVISIONS

- A. Signs shall not be attached to or placed upon any portion of a fire escape and shall not in any way interfere with the activities of the Fire Department or other public emergency services.
- B. No sign shall be erected, constructed, or maintained so as to obstruct free egress from a window, door or fire escape, to interfere with any opening required for ventilation, or to become a menace to life, health or property.
- C. No sign shall be of a shape, color, or design that may be confused with any authorized traffic control device.
- D. No rotating beam, beacon, or flashing illumination resembling an emergency light shall be used with any sign display.

## §215-34.8

## DESIGN &amp; CONSTRUCTION

- A. As a condition to the continuance or issuance of a permit pursuant to this Article, the Code Enforcement Officer may require the owner or applicant to furnish engineering data from an engineer licensed by the State of New York evidencing compliance with this Article.
- B. In general, all signs shall be permanently mounted and securely anchored. All ground signs must be sufficiently secured to prevent movement from wind.
- C. All signs shall be designed according to generally accepted engineering practices to withstand wind pressure at any point on the sign and from any direction as follows:

HEIGHT (GROUND TO TOP OF SIGN)	WIND PRESSURE (LBS/SF)
<i>Under 25 ft</i>	<b>25</b>
<i>25-75 ft</i>	<b>35</b>
<i>76-90 ft</i>	<b>45</b>
<i>Over 90 ft</i>	<b>50</b>

- D. The loads shall be distributed to the structural members of the sign in such a way that these members will not be over-stressed.
- E. All signs shall be constructed of permanent, weather resistant, and durable materials, except for banners, flags, temporary signs, and window signs otherwise in conformance with this Article.
- F. All sign lettering shall be permanently affixed to the sign. Ground signs utilizing manual changeable copy shall be enclosed.
- G. No sign may be constructed of untreated, unfinished, or unpainted wood, or sandblasted metal. All wood components of signs must be sealed and protected from the elements.
- H. All signs in excess of 40 square feet of face area must be constructed of incombustible material, except that moldings and cappings may be of wood or other combustible material.

**§215-34.9**

**ILLUMINATION**

- A. A sign illuminated by electricity or equipped in any way with electric devices or appliances shall require the issuance of an electrical permit in accordance with Chapter 54 of the Town of Tonawanda Code.
- B. Any illuminated sign or lighting device, other than a billboard sign in conformance with this Article, shall employ only lights emitting a light of constant intensity, and no sign shall be illuminated by or contain a flashing, intermittent, rotating or moving light or lights.
- C. In no event shall any illuminated sign or lighting device be placed to permit the beams and illumination therefrom to be directed upon a public street, highway, sidewalk or adjacent premises so as to cause glare or reflection that may constitute a traffic hazard or nuisance.
- D. The full number of illuminating elements of a sign shall be kept in working condition or immediately repaired or replaced.
- E. Overhead wires or exposed wires on a sign or its supporting members are prohibited.

- F. All lighting fixtures shall be dark sky compliant and directed so as not to cast an illumination of more than two foot-candles on adjacent nonresidential properties or more than three-tenths (0.3) of a foot-candle on adjacent residential properties.

### §215-34.10

#### LOCATION

---

- A. All signs and displays of merchandise must comply with the unobstructed vision clearance requirements of § 215-25.1 of this Chapter of the Code of the Town of Tonawanda.
- B. No sign shall obscure, alter, or cover the architectural features of any building.
- C. All signs shall be located on the same property for which the sign is intended to be applicable, with the exception of billboards as provided herein.
- D. All signs shall maintain at least a 10-foot setback from all property lines, unless otherwise noted within this Article.

### §215-34.11

#### MAINTENANCE & REPAIR

---

- A. All signs shall be maintained in safe and good structural condition, in compliance with all applicable building and electrical codes, and in conformance with this Article at all times.
- B. Such maintenance includes replacement of all defective bulbs, parts, materials, painting, repainting, cleaning, replacement of copy, and other acts required for maintenance of such sign.
- C. If any sign does not comply with these standards, the Code Enforcement Officer may require its removal.

### §215-34.12

#### REMOVAL OF SIGNS

---

- A. Signs no longer in use must be removed from the premises.
- B. Where required by this Article, the removal of signs shall be the sole responsibility of the property owner. If said sign is not removed within 30 days of the date of written notice by the Code Enforcement Officer, the Code Enforcement Officer or designee is authorized to affect its removal.
- C. The Code Enforcement Officer may remove any sign that is found to be in violation of this Article. The property owner shall subsequently be given written notice of such sign removal. If the sign is not claimed within 30 days of the written notice, the Code Enforcement Officer may dispose of the removed sign.
- D. Any costs incurred for the removal of a sign shall be fully reimbursed to the Town of Tonawanda by the sign permit holder. Such costs may be assessed to the property for collection by the Town.
- E. In the event that a sign has been damaged and presents an immediate threat to the public, the Code Enforcement Officer shall notify the owner or lessee of the property on which the sign is located, or the permittee, to remove the sign or place it in a safe condition. If such owner, lessee or permittee shall refuse or neglect to remove or place the sign in a safe condition within three days after the giving of such notice to the owner, lessee or permittee, the Town may cause the sign to be removed or made safe, and the expense thereof shall be assessed against the premises on which the sign was located.

- F. In the case of an emergency, the Code Enforcement Officer may cause immediate removal of such sign after giving such notice as is practical under the circumstances.

## §215-34.13

## SIGNS AUTHORIZED WITHOUT A PERMIT

The types of signs listed below are exempt from the requirement of a permit. In addition, the face area and number of such exempt signs shall not be counted in determining compliance with the provisions of this Article. Although permits are not required for these signs, they shall conform to all other requirements of this Article or may be subject to removal by the Code Enforcement Officer.

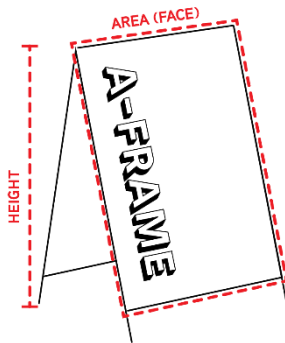

- A. **A-Frame Signs.** A-frame signs shall not require a permit provided the following conditions are met:
1. The sign is located in a nonresidential district and does not interfere with vehicular, pedestrian, or bicycle access or visibility.
  2. There is no more than one a-frame sign per use and the sign does not exceed four feet in height and eight square feet in area.
  3. The sign is not illuminated.
  4. The sign is brought in each day at the close of business.
  5. The Code Enforcement Officer may permit the placement of a-frame signs in the public right-of-way provided the proposed location does not violate Subsection 1 above.
- B. **Directional and Incidental Signs.** Freestanding signs that provide direction to pedestrians, bicyclists, or motorists, and signs erected to identify addresses, warnings, hours and days of operation, and the like, shall not require a sign permit provided the following conditions are met.
1. All signs are located entirely on the property to which they pertain.
  2. No sign exceeds an area of six square feet in a residential district, or 12 square feet in a nonresidential district, and is no more than three feet in height. The cumulative area of all signs shall not exceed 12 square feet in a residential district, or 16 square feet in a nonresidential district.
  3. Signs located within residential districts are not illuminated.
  4. No sign extends above the first floor of any given structure nor projects beyond property lines.
- C. **Governmental Signs.**
1. Signs erected and maintained pursuant to and in discharge of any governmental function, including state or federal historic markers, or required by any law, ordinance, or governmental regulation.
  2. Flags, emblems or insignias of the United States, the State of New York, other countries and states, the United Nations, or similar organizations of which this nation is a member.
- D. **Internal Signs.** Signs within a building not legible from the public right-of-way or adjacent lots, or any sign within an enclosed outdoor space, such as an athletic field, where such sign is intended only to be seen from within the enclosed space and is so oriented.



- E. Lawn Signs.** Lawn signs shall be allowed on any lot without a permit provided the following conditions are met.
  1. No single sign exceeds three feet in height and six square feet in area.
  2. The cumulative area of all signs on the lot does not exceed 16 square feet.
  3. The sign is not illuminated.
  4. The sign is not displayed for more than 60 days in a 180-day period.
  5. In the case of political signs, all signs shall be removed within 10 days after the close of the election.
  6. In the case of construction signs, all signs shall be removed within 10 days after the substantial completion of the project.
- F. Memorial or Historic Signs.** Memorial tablets or signs, locally designated historic markers, names of buildings and dates of erection when cut in any masonry surface or when constructed of bronze or any other noncombustible material.
- G. Neon Signs.** Neon signs are permitted in nonresidential districts without a permit, provided they conform to the following:
  1. The signs are mounted internally and located within a designated window area.
  2. The cumulative area of such signs does not exceed 15% of the window area.
  3. There are no more than three signs per use.

## §215-34.14

### PROHIBITED SIGNS

The construction, erection, alteration, reconstruction, display, ownership, maintenance or operation of any sign within the Town except as provided by this Article is hereby prohibited. The following types of signs are prohibited:

- A.** Any sign for which no sign permit was issued, for which a sign permit was revoked, or any other sign not explicitly authorized herein.
- B.** Any sign that is not properly maintained, considered structurally unsound, hazardous, or otherwise unsafe.
- C.** Any sign on a utility pole, tree, rock, ledge or other natural feature, whether on public or private property.
- D.** Any sign that is no longer applicable or relevant to the use of the premises on which the sign is located.
- E.** Any sign that is located off-premise from the use and/or structure to which it serves, except for billboards as provided by this Article.
- F.** Any sign that contains words or pictures of an obscene or pornographic nature.
- G.** Any sign that emits audible sounds, odor, or visible matter.
- H.** Any sign that may be confused with a traffic control sign, signal or device or the light of an emergency or road equipment vehicle or any sign which hides from public view any traffic or street sign, signal, or device.

- I. Any sign that flashes, blinks, rotates, or revolves, or utilizes unshielded lighting devices, mirrors, or reflective material.
- J. Any sign that is mounted on wheels or mounted on any structure on wheels.
- K. Any sign placed on or otherwise adhered or affixed to a motor vehicle or trailer and parked with the primary purpose of serving as signage for the use.
- L. Any permanent sign on an undeveloped site, except for subdivision signs.
- M. Any sign overhanging, encroaching upon, or located within the public right-of-way except as provided by this Article.

## §215-34.15

### SIGN DESIGN GUIDELINES

---

The following sign design guidelines are intended to provide applicants with guidance for best practices in addressing issues related to sign compatibility, legibility, placement, and color.

#### A. Compatibility.

1. Signs should be constructed of high-quality materials compatible with the building form and desired character of the area in which they are located.
2. Signs should be appropriately scaled for the building or site upon which they are located, so as not to dominate the façade or streetscape.
3. Signs on buildings that have a monolithic or plain façade should be used to create visual interest through appropriate sign design features, scale, and proportions.
4. Signs should be designed to include relief in the lettering or sign face to create shadows and provide depth and visual interest.

#### B. Legibility.

1. Hard to read, intricate typefaces should be avoided. The variation of lettering styles on a single sign should be limited to two for small signs and three for larger signs.
2. Letters and words should not be spaced too closely together. Generally, letters should not occupy more than 75% of the sign area.
3. Large areas of blank spaces should be avoided. Generally, 50% or more blank area should be avoided for boxed sign areas or framed signs.
4. Signs should have the minimum of information necessary in order to avoid clutter and confusion. Whenever feasible, signs should be combined into a single sign in order to minimize clutter.

#### C. Placement.

1. Signs should be so located to respect and compliment a building's façade, utilizing logical signage areas created by existing architectural details or ornamentation.
2. Signs should be placed at or near the public entrance to a building to indicate the most direct access.

#### D. Color.

1. Signs should feature substantial contrast between the color and material of the background and text, graphics, or symbols.
2. Sign colors should complement the materials and colors of adjacent buildings, including accent and trim colors, where applicable.
3. Use of color and color combinations utilized for signs should be limited. Generally, a sign should not utilize more than three colors, including accent colors.
4. Day-glo or florescent colors should be avoided.

§215-34.16

REGULATIONS BY ZONING DISTRICT

- A. The following table indicates the number and types of signs permitted in the Town of Tonawanda by zoning district.
1. A "●" indicates that the sign type is permitted and may be illuminated.
  2. A "○" indicates that the sign type is permitted but may not be illuminated.
  3. A "-" indicates the sign type is prohibited.

ZONING DISTRICT	MAX # OF SIGN TYPES (PER USE)	AWNING OR CANOPY	BILLBOARD	GROUND	MARQUEE	POLE	PROJECTING	ROOF	SUSPENDED	WALL	WINDOW <sup>2</sup>	TEMPORARY <sup>2</sup>
<i>R-1, R-2, MR</i>	1	-	-	○	-	-	-	-	-	○	○	○
<i>MU-N</i>	2	● <sup>1</sup>	-	●	-	-	●	-	●	●	○	○
<i>MU-GC</i>	2	●	-	●	●	●	●	-	●	●	○	○
<i>MU-W</i>	2	●	-	●	●	-	●	-	●	●	○	○
<i>MU-I, GI</i>	2	●	● <sup>1</sup>	●	●	●	●	●	●	●	○	○
<i>CF, OS</i>	-	-	-	●	-	-	-	-	-	●	○	○

Regulations by Sign Type												
§215-34.18	A	B	C	D	E	F	G	H	I	J	K	

- NOTES:**
- (1) Illumination shall be located in the area underneath the awning or canopy. No bulb or illumination device shall hang below the valence area.
  - (2) Billboard signs are only allowed on parcels that adjoin the Elmer G.H. Youngmann Expressway or the Niagara Section of the NYS Thruway.
  - (3) Window and temporary signs shall not count towards the maximum number of signs for any given use.

§215-34.17

UNIQUE BUILDING & DEVELOPMENT CONFIGURATIONS

There are certain building and development configurations that warrant the permission of additional signage to provide adequate visibility and identification for motorists, pedestrians, and bicyclists. The following table indicates the permitted number of signs and sign types for such certain building and development configurations. Unless noted as additional signage, these regulations shall supersede those of Subsection A above.

CONFIGURATION	PERMITTED SIGN TYPE & STANDARDS
<b>Single- or Multi-Family Residential Development</b>	
<i>Per Entrance<sup>1</sup></i>	<b>One additional ground sign, in conformance with §215-34.18 C</b>
<b>Campus Style Development</b>	
<i>Per Entrance<sup>1</sup></i>	<b>One additional ground sign, no more than 40 sf in area and 8 ft in height</b>
<b>Mixed-Use or Multi-Tenant Commercial Development</b>	
<i>Per Use or Tenant</i>	<b>Up to 2 sign types in conformance with §215-34.18, except ground and pole signs</b>
<i>Per Entrance</i>	<b>One ground or pole sign not exceeding 60 sf in area</b>
<b>Multi-Story, Mixed-Use or Multi-Tenant Commercial Building</b>	
<i>Per First-Floor Use</i>	<b>Up to 2 different sign types in conformance with §215-34.18</b>
<i>All Upper Floor Uses</i>	<b>One shared wall, projecting, or suspended sign in conformance with §215-34.18</b>

**NOTE:** (1) The additional signage shall be permitted only at entrance points from public streets and/or streets designated as primary entrances.

§215-34.18

REGULATIONS BY SIGN TYPE

**A. Awning or Canopy Sign.** A sign that is part of or attached to a roof-like protective cover of canvas or other flexible material over a door, entrance, window or outdoor service area that projects from the façade of a structure.

- All awning or canopy signs shall be in conformance with the standards of the following table.

<i>Max Number</i>	<b>1 per Awning/Canopy Structure</b>
<i>Max Area</i>	<b>50% of Valence Area</b>
<i>Max Height</i>	<b>-</b>
<i>Min Ground Clearance</i>	<b>9 ft</b>
<i>Illumination</i>	<b>Permitted</b>

- Additional Regulations.
  - Awning signs shall be limited to the valence area.
  - A single use may utilize no more than two awnings for signage. Where a single use has more than one awning, each awning shall match in color and style.

- c. Where an awning relates to more than one use, each use shall be entitled to one sign on such awning provided the color and style of the signs are the same.
- d. Awnings upon which a sign is to be placed shall be comprised of high-quality, weather-resistant materials designed for exterior use.

**B. Billboard Sign.** Any sign that attracts attention to an object, product, service, place, activity, institution, organization, or business not available or not located on the premises where the sign is located.

1. All billboard signs shall be in conformance with the standards of the following table.

<i>Max Number</i>	-
<i>Max Area</i>	<b>672 sf</b>
<i>Max Height <sup>1</sup></i>	<b>45 ft</b>
<i>Min Ground Clearance</i>	<b>10 ft</b>
<i>Max Area of Temporary Embellishments</i>	<b>20% of Face Area</b>
<i>Min Distance from Residential Districts</i>	<b>50 ft</b>
<i>Min Separation between Billboards on Same Side of Highway</i>	<b>1,000 ft</b>
<i>Min Setback</i>	<b>Follow District Requirements (See Part 2)</b>

**NOTE:** (1) Measured from the grade of the thoroughfare adjacent to which the billboard is located

2. Additional Regulations.

- a. Billboard signs are permitted to use digital technology for the entire allowable sign face area, provided all applicable regulations of this Article are met.
- b. Billboard signs shall not portray or advertise products containing alcohol, tobacco, or an adult use.

**C. Ground Sign.** A sign not attached to any building or structure, which may be flush with the ground or supported by two columns or posts provided the distance between the ground and bottommost edge of the sign is no greater than three feet.

1. All ground signs shall be in conformance with the standards of the following table.

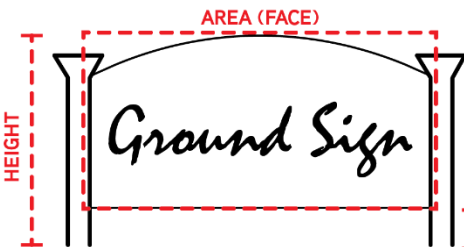

ZONING DISTRICT	R-1, R-2, MR	MU-N, MU-GC, CF, OS	MU-W, MU-I, GI
<i>Max Number</i>	<b>1 per Lot</b>	<b>1 per Lot</b>	<b>1 per Building</b>
<i>Max Area</i>	<b>6 sf</b>	<b>24 sf</b>	<b>40 sf</b>
<i>Max Height</i>	<b>3 ft</b>	<b>4 ft</b>	<b>10 ft</b>
<i>Min Separation between Signs on Same Premises</i>	-	-	<b>50 ft</b>
<i>Min Setback</i>	<b>15 ft</b>	<b>15 ft</b>	<b>15 ft</b>

2. Additional Regulations.

- a. No ground sign shall be permitted where the principal structure on the lot has a front setback of less than 15 feet.
- b. All ground signs must be sufficiently secured to prevent movement from wind.
- c. Ground signs and pole signs may not be used in combination on the same premises.
- d. All ground signs shall have a landscaped area at the base of the sign. The landscaping shall fully surround the sign and utilize appropriate plantings so as not to obscure the visibility of the sign.
- e. All plantings shall be properly manicured and maintained as the season may require. Dead or decaying plant material shall be replaced within 30 days of written notice by the Code Enforcement Officer.
- f. External lighting fixtures may be mounted on the ground or on the sign. Lighting fixtures mounted on the ground shall be shielded and directed to illuminate only the sign face.

D. Marquee Sign

- 1. No building or use may have more than one marquee sign.
- 2. All location, dimensional, and illumination requirements for marquee signs shall be determined with review and approval by the Planning Board.

E. Pole Sign. A sign not attached to any building or structure, which may be supported by one or two columns or posts where the distance between the ground and bottommost edge of the sign is at least 10 feet.

- 1. All pole signs shall be in conformance with the standards of the following table.

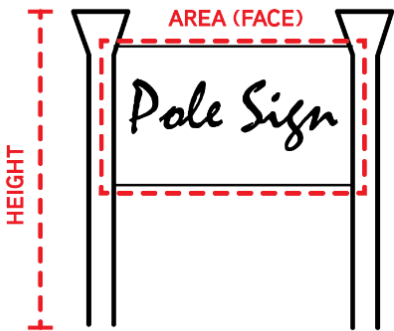

LOT STREET FRONTAGE	<30 FT	30-60 FT	30-120 FT	>120 FT
<i>Max Number</i>	-	1	2	3
<i>Max Area</i>	-	120 sf	120 sf (60 sf each)	120 sf (60 sf each)
<i>Max Height<sup>1</sup></i>	-	30 ft	30 ft	30 ft
<i>Min Separation between Signs on Same Premises</i>	-	-	50 ft	50 ft
<i>Min Setback</i>	-	2 ft	2 ft	2 ft

NOTE: (1) Maximum height shall include the distance from the ground.

2. Additional Regulations.

- a. No sign shall be permitted where the principal structure on the lot has a front setback of less than 10 feet.
- b. Nothing shall be painted on or affixed below the required ground clearance.
- c. No pole sign shall be located so as to create a visual obstruction from or within a public right-of-way.

- d. A pole sign support may include a double-pole support structure with supports of up to 12 inches in diameter and, should architectural skirting be utilized, supports may be up to 24 inches in diameter.
- e. All pole signs shall have a landscaped area at the base of the sign. The landscaping shall fully surround the sign and utilize appropriate plantings so as not to obscure the visibility of the sign.
- f. All plantings shall be properly manicured and maintained as the season may require. Dead or decaying plant material shall be replaced within 30 days of written notice by the Code Enforcement Officer.
- g. External lighting fixtures may be mounted on the sign only.

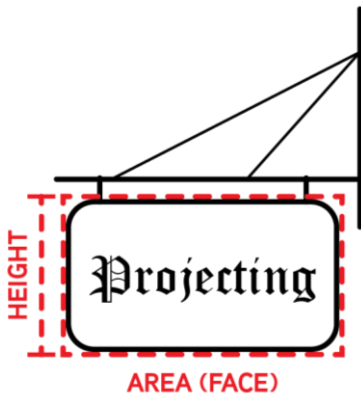

**F. Projecting Sign.** A sign which is wholly dependent upon a building for support and which projects more than 12 inches from such building.

- 1. All projecting signs shall be in conformance with the standards of the following table.

ZONING DISTRICT	MU-N, MU-GC, MU-W	MU-I, GI
<i>Max Number</i>	<b>1 per use</b>	<b>1 per use</b>
<i>Max Area</i>	<b>1 sf per ft of building frontage</b>	<b>1 sf per ft of building frontage <sup>1</sup></b>
<i>Max Height</i>	<b>2 ft</b>	<b>3 ft</b>
<i>Min Ground Clearance</i>	<b>10 ft</b>	<b>10 ft</b>

**NOTE:** (1) The combined total area for wall, projecting, and roof signs in the MU-I and GI districts shall not exceed 5 square feet per 1 foot of building frontage.

**G. Roof Sign.** Sign that is supported on the top of a building or structure and constructed of a noncombustible material.

- 1. All roof signs shall be in conformance with the standards of the following table.

<i>Max Number</i>	<b>1 per building</b>
<i>Max Area</i>	<b>5 ft per ft of Building Frontage <sup>1</sup></b>
<i>Max Height above Roof (site of attachment)</i>	<b>15 ft</b>

**NOTE:** (1) The combined total face area for wall, projecting, and roof signs in the MU-I and GI districts shall not exceed 5 square feet per 1 foot of building frontage.

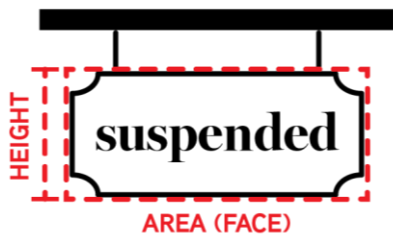

**H. Suspended Sign.** A sign attached to and supported by the underside of a horizontal plane.

1. All suspended signs shall be in conformance with the standards of the following table.

ZONING DISTRICT	MU-N, MU-GC, MU-W	MU-I, GI
<i>Max Number</i>	<b>1 per use</b>	<b>1 per use</b>
<i>Max Area</i>	<b>1 ft per ft of Building Frontage</b>	<b>1 ft per ft of Building Frontage</b>
<i>Max Height</i>	<b>2 ft</b>	<b>3 ft</b>
<i>Min Ground Clearance</i>	<b>10 ft</b>	<b>10 ft</b>

**I. Wall Sign.** A sign fastened to the wall of a building or structure in such a manner that the wall becomes the supporting structure for or forms the background surface of the sign and which does not project outward more than 12 inches from such building or structure.

1. All wall signs shall be in conformance with the standards of the following table.

ZONING DISTRICT	R-1, R-2, MR	MU-N, MU-GC, MU-W	MU-I, GI
<i>Max Number</i>	<b>1 per use</b>	<b>1 per use</b>	<b>1 per façade</b>
<i>Max Area</i>	<b>2 sf</b>	<b>3 sf per ft of Building Frontage OR 300 sf<sup>1</sup></b>	<b>4 sf per ft of Building Frontage<sup>2</sup></b>
<i>Max Height</i>	<b>2 ft</b>	<b>4 ft</b>	<b>6 ft</b>
<i>Min Ground Clearance</i>	<b>5 ft</b>	<b>5 ft</b>	<b>5 ft</b>

**NOTES:** (1) Whichever is less.  
 (2) The combined total face area for wall, projecting, and roof signs in the MU-I and GI districts shall not exceed 5 square feet per feet of building frontage.

2. Additional Regulations.
  - a. Wall signs shall not extend beyond the ends of the wall surface.
  - b. Painted wall signs may be permitted with Planning Board approval.
  - c. The maximum size requirements may be exceeded with Planning Board approval.



**J. Window Sign.** A sign visible from a sidewalk, street, or other public place, painted or affixed on glass or other window material, or located inside within three feet of the window, but shall not include graphics in connection with customary display of products.

1. All window signs shall be in conformance with the standards of the following table.

<i>Max Number</i>	-
<i>Max Area</i>	<b>20% of Window Area</b>
<i>Max Height</i>	-
<i>Min Ground Clearance</i>	-

**K. Temporary Sign.** A sign which is not intended to be used for a period exceeding 60 days and is not attached to a building, structure, or ground in a permanent manner.

1. All temporary signs shall be in conformance with the standards of the following table.

<i>Max Number</i>	<b>1 per use</b>
<i>Dimensional Requirements</i>	<b>See Sign Type Most Closely Aligned with Style of Temporary Sign</b>

2. Additional Regulations. Temporary signs shall not be displayed for more than 60 days in a 190-day period. This may be extended for up to two additional 60-day periods upon written request to the Code Enforcement Officer setting forth the special circumstances requiring such extension.

**§215-34.19**

**DIGITAL SIGNS**

The following requirements shall apply to any sign utilizing digital technology.

- A. The use of digital sign technology shall be limited to districts where illumination is permitted.
- B. The extent of sign face area utilizing digital sign technology, including any screens or other display area, shall not exceed 50%. Billboards are exempt from this provision.
- C. Digital technology shall not be utilized in any wall sign, projecting sign, suspended sign, awning sign, or window sign.
- D. Digital signs shall display static messages with no animation, no effects simulating animation, and no video.
- E. Changes in copy, message, or graphics shall occur no more than once every 60 seconds.
- F. Each transition shall be accomplished immediately with no fade, scroll, flash, spin, revolve, or shake or include any other type of movement or motion.

- G. Digital signs shall be equipped with photosensitive equipment that is programmed to automatically adjust the brightness and contrast of the sign in direct relation to the ambient outdoor illumination.
- H. The illuminance of a digital sign shall be measured with an illuminance meter set to measure footcandles accurate to at least two decimals. Illuminance shall be measured with the digital sign off, and again with the digital sign displaying a white image for a full color-capable sign, or a solid message for a single-color sign. All measurements shall be taken at a height of at least five feet and a distance determined by the following calculation. All fractions shall round up to the nearest foot.  
  
*Measurement Distance =  $\sqrt{(Area\ of\ Sign\ in\ Square\ Feet\ x\ 100)}$*
- I. The difference between the digital sign measurements when off and when displaying a solid-message (using the digital sign measurement criteria) shall not exceed 0.3 footcandles, regardless of ambient lighting conditions.
- J. All digital signs shall be equipped with a sensor or other device that automatically determines the ambient illumination and programmed to automatically dim according to ambient light conditions, or that can be adjusted to comply with the 0.3 footcandle measurements.
- K. Digital signs shall be programmed or set in such a manner that the display will turn dark and emit no light in case of malfunction.
- L. No digital sign shall be located within 50 feet of a residential district or use as measured in a straight line from the location of the sign to the nearest residential property line.

## §215-34.20

### NONCONFORMING SIGNS

- A. Any sign that does not comply with this Chapter is eligible for characterization as a legal nonconforming sign if the sign complied with all requirements in effect at the time it was erected.
- B. Nonconforming signs must be brought into compliance with this Chapter under the following conditions:
  1. The sign is altered in any way, such as size, design, structure, or type of illumination (except for normal maintenance).
  2. The sign is relocated.
  3. The sign or its structural materials are wholly replaced.
- C. Any nonconforming sign that is removed from its position or siting and not replaced in-kind within 90 days shall be presumed to be abandoned and discontinued, and therefore may not be restored or re-erected except in compliance with this Chapter.
- D. No nonconforming sign may be altered in any way that would increase its nonconformity with the regulations of this Chapter, including but not limited to area, height, setback, and illumination.
- E. Nothing in this section shall relieve the owner or user of a nonconforming sign or owner of the property on which the nonconforming sign is located from complying with the provisions of this Chapter regarding safety, maintenance and repair of signs. Any repainting, cleaning, or routine maintenance or repair of the sign or sign structure shall not be deemed to modify the sign in any way.